

A PROTOTYPE CAVITY BEAM POSITION MONITOR FOR THE CLIC MAIN BEAM*

F. Cullinan[†], S.T. Boogert, N. Joshi, A. Lyapin, JAI at Royal Holloway, Egham, UK
D. Bastard, E. Calvo, N. Chritin, F. Guillot-Vignot, T. Lefevre, L. Sjøby, M. Wendt, CERN, Geneva
A. Lunin, V.P. Yakovlev, Fermilab, Batavia, USA
S. Smith, SLAC, Menlo Park, California

Abstract

The Compact Linear Collider (CLIC) places unprecedented demands on its diagnostics systems. A large number of cavity beam position monitors (BPMs) throughout the main linac and beam delivery system (BDS) must routinely perform with 50 nm spatial resolution. Multiple position measurements within a single 156 ns bunch train are also required. A prototype low-Q cavity beam position monitor has been designed and built to be tested on the CLIC Test Facility (CTF3) probe beam. This paper presents the latest measurements of the prototype cavity BPM and the design and simulation of the radio frequency (RF) signal processing electronics with regards to the final performance. Installation of the BPM in the CTF3 probe beamline is also discussed.

INTRODUCTION

The CLIC design for 3 TeV centre of mass energy includes a 40 km long main linac and a 6 km long beam delivery system which require precise beam position monitoring for operation. This will be achieved using close to 4800 cavity beam position monitors, one for each of the 4196 quadrupole magnets in the main linac and a further 600 in the BDS. These must have a good spatial resolution of 50 nm and a time resolution of 50 ns in order to provide multiple, accurate position measurements within a single bunch train. They must also operate in an environment where large shifts in temperature are expected [1].

A prototype cavity BPM has been designed and built to be tested on the CTF3 probe beam later this year. It consists of two cavities, a position cavity and a reference cavity. The position cavity is a cylindrical pillbox with rectangular waveguides that strongly couple to the first resonant dipole mode in two polarisations (TM_{110}). The amplitude of each polarisation is proportional to the beam offset in one transverse dimension. The dipole mode frequency of 14.99 GHz is close to 14 GHz which will be used for CLIC. It was chosen so that signals from consecutive bunches, separated by 0.667 ns (0.5 ns for CLIC), add constructively and dominate signals from other modes excited by the beam. The reference cavity is re-entrant and its first monopole mode (TM_{010}) is used for bunch charge normalisation and as a reference beam arrival phase. It has the same frequency

*The research leading to these results has received funding from the European Commission under the FP7 Research Infrastructures project EuCARD, grant agreement no.227579, DITANET under EU contract PITN-GA-2008-215080 and the STFC; Computing time with ACE3P provided by US DOE at NERSC

[†]Francis.Cullinan.2010@live.rhul.ac.uk

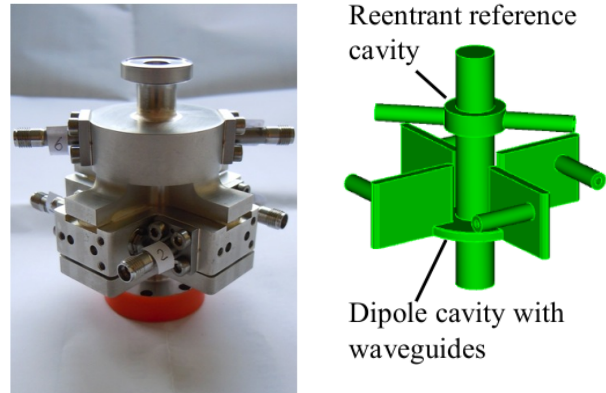

Figure 1: The brazed prototype pick-up assembly (left) and the vacuum geometry (right) with fitted feedthroughs.

as the position cavity first dipole mode so that the same signal processing can be applied to both for improved stability. Both cavities are designed to have low quality factors in order to achieve a good time resolution. The beam pipe through the assembly has the same 4 mm radius as the CLIC main linac [2].

A photograph of the two cavity assembly, which consists of four stainless steel parts brazed together, is shown in Fig. 1. The signals are extracted via feedthrough antennas in the re-entrant part of the reference cavity and in the case of the position cavity, at the end of the waveguides where there are also tuning bolts. These push against the wall of each waveguide opposite the antenna to tune the antenna coupling to the dipole mode resonant frequency. Each opposing pair of feedthrough antennas in the position cavity measure the same dipole mode polarisation. Combination of the two signals is not intended but having two means a lower external quality factor and leaves the option to suppress the TM_{210} quadrupole mode using a 180° hybrid or to compensate for cross coupling with adjustable short-circuit terminations. The signal from one of the two feedthrough antennas in the reference cavity could also be diode rectified for timing measurements [3].

The prototype pick-up was brazed at the end of April and the feedthroughs, which are aligned with dowel pins and sealed with silver-coated copper gaskets, were fitted afterwards by hand. The assembly then successfully passed a vacuum test. This paper describes the latest RF measurements of the cavity, progress towards developing down-conversion electronics and finally, beam test plans.

RESONANT MODE MEASUREMENTS

The quality factors of the first dipole mode of the position cavity and the monopole mode of the reference cavity were measured before [4] and after brazing. This was done using the transmission of a weakly coupled antenna positioned in the beampipe to each output port in turn with the remaining ports either short-circuited or terminated with matched loads. The quality factors, both loaded Q_L and internal Q_0 could then be determined as outlined in [4].

Table 1: Quality factors and resonant frequency f_0 of the position cavity first dipole mode measured before and after brazing.

Parameter	Predicted	Before brazing	After brazing
f_0/GHz	14.990	14.993	15.012
Q_L	274	224	198
Q_0	450	306	292

Table 2: Quality factors and resonant frequency f_0 of the reference cavity first monopole mode measured before and after brazing.

Parameter	Predicted	Before brazing	After brazing
f_0/GHz	14.999	14.960	14.997
Q_L	150	74	130
Q_0	383	-	357

The measured quality factors and resonant frequencies are shown in Tables 1 and 2. In the case of the position cavity, an increase of about 20 MHz in frequency and a decrease in the quality factor were observed after brazing. The value for the internal quality factor of the reference cavity before brazing is missing. This is because the reference cavity had to be modified [4] and the measurements were taken simply to confirm the correct resonant frequency had been achieved. For the same reason, the predicted values were taken from simulations in Omega3p, the ACE3P eigenmode solver [5], since no simulations of the modified cavity were performed at the design stage. The resonant frequency increased by 37 MHz and the loaded quality factor increased by a factor of almost two during brazing. These changes are consistent with the correct positioning of the feedthrough antennas with the gaskets in place as predicted in simulation [4].

After the measurements had been made, an attempt was made to tune the position cavity using the tuning bolts. In this way, the coupling could be balanced between the waveguides but the process was not completely reversible and didn't always result in an improvement. The maximum cross coupling between a pair of adjacent output ports was -38 dB and this did not improve noticeably during tuning. The cross coupling between the other pairs of adjacent ports were all below -40 dB.

ISBN 978-3-95450-119-9

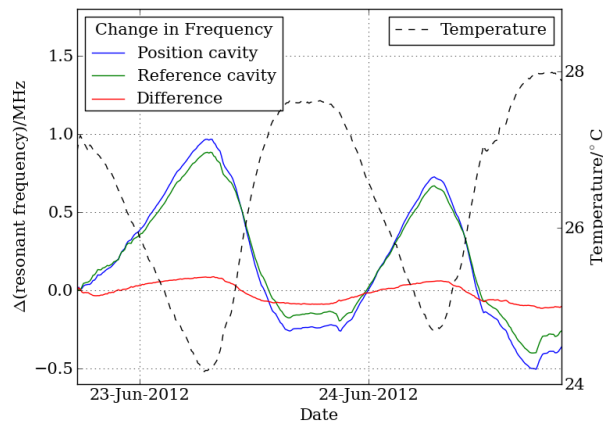

Figure 2: Variation of the resonant frequencies of the position cavity dipole and reference cavity monopole modes over time.

The stability of the resonant frequency with temperature was also measured for both modes. The assembly was left over one weekend and the resonant frequencies were measured from the transmission spectra between opposite ports every ten minutes. The temperature was also recorded as shown in Fig. 2. The temperature stability of the position cavity first dipole mode, as measured from fits of resonant frequency against temperature, was $-359 \text{ kHz}/^\circ\text{C}$ which is worse than the previous measurement of $-243 \text{ kHz}/^\circ\text{C}$ [4]. This is possibly due to the vacuum sealing of the feedthrough antennas. The temperature stability of the reference cavity monopole mode, $-308 \text{ kHz}/^\circ\text{C}$, is significantly lower, giving a relative temperature stability of the two modes of $51 \text{ kHz}/^\circ\text{C}$. Over the 20°C maximum temperature shift expected during CLIC operation, this corresponds to a relative frequency shift of 1 MHz, which will certainly be significant when looking at measurements of one or a few bunches and so may need to be improved. This could possibly be achieved by using a reference cavity that is a pillbox, similar to the position cavity.

SIGNAL PROCESSING

A schematic of the signal processing electronics to be used for the beam tests is shown in Fig. 3. There is a filter stage at RF to remove unwanted modes. However, the bandwidth must be kept larger than twice the bandwidth of the cavity so as not to have a significant effect on the rise time of the multiple bunch signal and degrade the temporal resolution. The electronics bandwidth also has a large effect on the maximum signal observed from a single bunch. A digitally controlled attenuator will be used to control the dynamic range. A 7 GHz lowpass filter is used to remove the high frequency outputs of the mixer and signals around 15 GHz while 800 MHz lowpass filters prevent aliasing in the high speed digitiser which was chosen because of availability. In order to avoid any complications with timing, a single independent voltage controlled oscillator (VCO) will

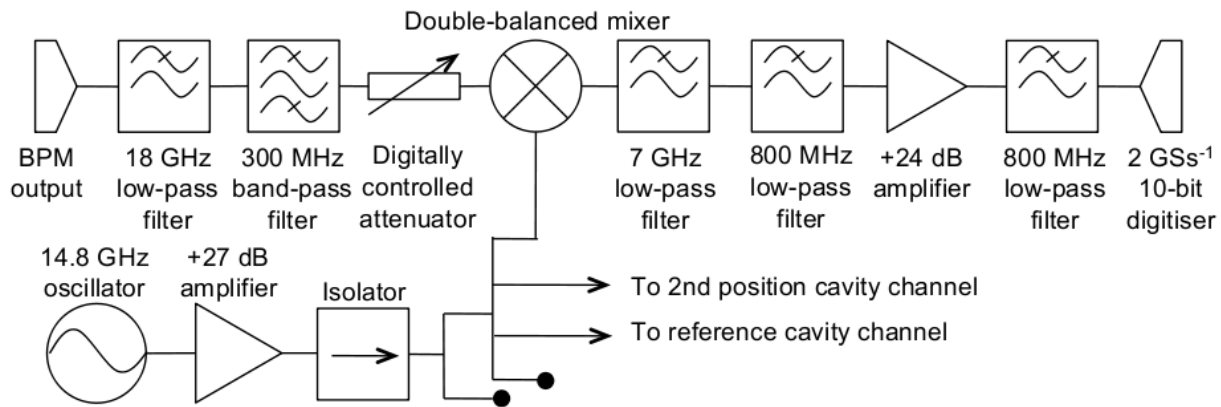

Figure 3: Diagram of the signal processing electronics to be used for the beam tests.

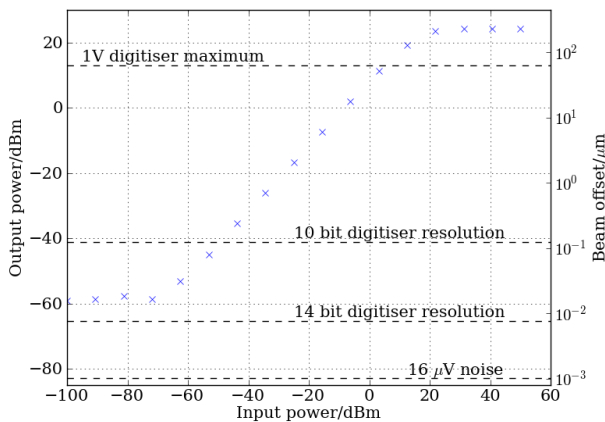

Figure 4: Simulated output power against input power in the electronics with the estimated corresponding offset.

be used for down-mixing to the 200 MHz intermediate frequency. The VCO can be driven to provide enough power for the nine channels required for three BPMs in the future. Before commissioning the electronics, schottky diode detectors will be used to obtain preliminary measurements of the BPM coupling to beam.

A simple simulation using the PYTHON package, wfproc [6], was performed in order to see the effect of the electronics in terms of gain and noise. The thermal noise of the system was estimated to be 16 μV and the results are shown in Fig. 4. The sensitivity of the pick-up was also calculated from the measured quality factors and the R/Q determined using Omega3p [5]. This was used to estimate a signal maximum of 0.6 V going into the electronics for a single bunch of 0.6 nC at 100 μm offset, taking into account the finite bandwidth of the electronics. Under these assumptions and with no added attenuation, the right-hand side vertical axis in Fig 4 shows the position offset corresponding to the calculated output power. The dynamic range of the electronics is limited by the double-balanced mixer and corresponds to $\pm 240 \mu\text{m}$ and a resolution limit of 14 nm is imposed by the electronics noise.

The digital signal processing will be crucial for obtaining the desired performance. Several possibilities are be-

ing pursued to achieve as many independent measurements as possible within a single train as well as high precision average position measurements. The former may employ deconvolution of the single bunch response from the overlapping signals of multiple bunches [7].

SUMMARY AND OUTLOOK

A prototype cavity BPM for the CLIC main beam has been designed and built. The RF characteristics of the assembly have been measured both before and after brazing and a complete temperature stability measurement has been made. The signal processing electronics have been designed and simulated and the results will be directly comparable with measurements of a full channel.

The BPM is scheduled to be installed at the end of the probe beamline at CTF3 [4] at the start of November for running until the end of 2012 and at the start of 2013. It will be mounted on a pair of stepper motor driven stages for measurement of the sensitivity and for calibration in both horizontal and vertical directions. A screen monitor just downstream of the pick-up will help to commission the new installation and ensure total beam transmission.

REFERENCES

- [1] Lefevre, T., 2011. "Overview of the CLIC Beam Instrumentation", IPAC2011, San Sebastian, Spain.
- [2] Schmickler, H. et al., 2010. "Submicron Multi-Bunch BPM for CLIC", IPAC2010, Kyoto, Japan.
- [3] Lunin, A., 2012. "High Resolution RF Cavity BPM Design for Linear Collider", 8th DITANET Topical Workshop on Beam Position Monitors, CERN, Switzerland.
- [4] Cullinan, F. et al., 2012, "Development of a Cavity Beam Position Monitor for CLIC", IPAC12, New Orleans, USA.
- [5] Ko, K. et al, "Advances in Parallel Electromagnetic Codes for Accelerator Science and Development", LINAC2010, Tsukuba, Japan.
- [6] Lyapin, A., 2011, "Welcome to wfprocs documentation!", <http://wfproc.sourceforge.net/>.
- [7] Smith, S., 2012. "Beam Position Monitors for the CLIC Drive Beam", 8th DITANET Topical Workshop on Beam Position Monitors, CERN, Switzerland.