

# DESIGN STATUS OF THE EUROPEAN X-FEL TRANVERSE INTRA BUNCH TRAIN FEEDBACK

Boris Keil, Raphael Baldinger, Carl David Beard, Micha Markus Dehler, Waldemar Koprek, Goran Marinkovic, Markus Roggli, Martin Rohrer, Markus Stadler, Daniel Marco Treyer,  
PSI, Villigen, Switzerland  
Vladimir Balandin, Winfried Decking, Nina Golubeva, DESY, Hamburg, Germany

## Abstract

The European X-Ray Free Electron Laser (E-XFEL) [1] will have a fast transverse intra-bunch train feedback (IBFB) system [2] to stabilize the beam position in the SASE undulators. E-XFEL bunch trains consist of up to 2700 bunches with a minimum bunch spacing of 222ns and typ. 10Hz train repetition rate. The IBFB will measure the positions of each bunch in the bunch train, and apply intra-train feedback corrections with fast kickers, in addition to a feed-forward correction for reproducible trajectory perturbations. By achieving a feedback loop latency in the order of one microsecond, the IBFB will allow the beam position to converge quickly to the nominal orbit as required for stable SASE operation. The latest conceptual design of the IBFB and the status of IBFB components will be presented.

## INTRODUCTION

The E-XFEL has a superconducting 17.5GeV main linac, with 0.1-1nC nominal bunch charge, and  $N \cdot 111$ ns bunch spacing, where  $N$  is an integer  $> 1$ . One distinct feature of the accelerator is its ability to generate bunch trains of up to 600 $\mu$ s length with arbitrary bunch patterns for the SASE undulators, where different parts of the same bunch train can be distributed to different undulator lines by means of a beam distribution system [3].

### Transverse Beam Stability

In order to achieve sufficient and reproducible intensity and pointing stability of the X-ray photon pulses generated in the E-XFEL SASE undulators, the electron beam should deviate less than  $\sim \sigma/10$  from its nominal (ideally straight) trajectory in the undulators, with typical beam sizes of  $\sigma=30\mu$ m or less depending on beam charge

and resulting emittance. However, due to a number of transverse perturbations sources, deviations of more than  $\sim \sigma/10$  from this trajectory are expected to occur without operational IBFB. Perturbations that are random, i.e. not reproducible, will be corrected by a fast intra bunch train feedback (IBFB) system can measure and correct the trajectory individually for each bunch. In addition, for perturbations that are reproducible from bunch train to bunch train (or change sufficiently slow) the IBFB will apply a static (or adaptive) feed-forward correction.

### Perturbation Sources, Frequencies, and Feedback Loop Latency

Table 1 shows the presently expected main horizontal (X) and vertical (Y) perturbation sources, their estimated worst-case peak amplitudes and necessary correction kicks [4], normalized to 30m beta function both at the location of position measurement and of the kicker. Since no significant random perturbations with very high frequencies are expected, we aim for a feedback loop latency of  $<1.5\mu$ s, allowing to correct non-reproducible perturbations up to a maximum (0dB) frequency of  $\sim 70$ kHz. Although a lower latency is possible, we favour a latency that is somewhat larger than the technically feasible minimum value, because this allows to use e.g. ADCs with higher resolution (having higher latency) for the BPMs, or more advanced FPGA algorithms to correct BPM RF front-end IQ imbalance and X/Y-coupling, thus reducing BPM-noise dominated perturbations that the IBFB adds to the beam. Since the IBFB kickers can apply arbitrary individual kicks for each bunch, the additional feed-forward corrections applied by the IBFB allow to correct reproducible perturbations of any frequency from several MHz down to DC within the available kick range.

Table 1: E-XFEL beam trajectory perturbation sources, estimated worst-case peak amplitudes, and frequencies

	X [ $\mu$ m]	Y [ $\mu$ m]	Frequency [kHz]	Plane	Perturbation Type	Kick(X) [ $\mu$ rad]	Kick(Y) [ $\mu$ rad]
Magnet Vibrations	$\pm 28$	$\pm 28$	$<1$	X/Y	Random	$\pm 1.0$	$\pm 1.0$
Power Supply Noise	$\pm 12.6$	$\pm 12.6$	$<1$	X/Y	Random	$\pm 0.5$	$\pm 0.5$
Vibration-Induced Dispersion Jitter	$\pm 2.5$	$\pm 2.5$	$<1$	X/Y	Random	$\pm 0.1$	$\pm 0.1$
Beam Distribution Kicker Drift	$\pm 0$	$\pm 1$	$<1$	Y	Repetitive	$\pm 0$	$\pm 0.04$
Beam Distribution Kicker Noise	$\pm 0$	$\pm 1$	$<5000$	Y	Random	$\pm 0$	$\pm 0.04$
Spurious Dispersion (3% Energy Chirp)	$\pm 15$	$\pm 15$	$<1$	X/Y	Repetitive	$\pm 0.5$	$\pm 0.5$
Nonlinear Dispersion (3% Energy Chirp)	$\pm 15$	$\pm 0$	$<1$	X	Repetitive	$\pm 0.5$	$\pm 0$
Spurious Dispersion (1E-4 Energy Jitter)	$\pm 0.5$	$\pm 0.5$	$<5000$	X/Y	Random	$\pm 0.02$	$\pm 0.02$
Nonlinear Dispersion (1E-4 Energy Jitter)	$\pm 0.15$	$\pm 0$	$<5000$	X	Random	$\pm 0.005$	$\pm 0$
Wakefields	$\pm 25$	$\pm 25$	$<5000$	X/Y	Repetitive	$\pm 0.9$	$\pm 0.9$
<b>Sum Of Peak Values</b>	<b><math>\pm 98.8</math></b>	<b><math>\pm 85.6</math></b>				<b><math>\pm 3.5</math></b>	<b><math>\pm 3.1</math></b>

## Quadrupole Magnet Vibrations

One source of random perturbations where the expected beam movement is significant is the vibration of quadrupole magnets in the cryostats of the linac, where the comparatively complex mechanical support structure is naturally not as stable as for normally conducting linacs where quadrupoles sit on simpler massive girders. Since the typical oscillation period of magnet vibrations is relatively high (~10-100ms) compared to a bunch train length of max. 0.6ms, the vibrations cause an overall trajectory perturbation that varies very slowly along the bunch train, with nearly the same perturbation amplitude and angle for adjacent bunches. Vibrations are therefore – despite their low perturbation frequency – one reason why a low-latency IBFB is required: When the IBFB detects the perturbation at the beginning of the bunch train and then starts applying corrections so that the following bunches converge towards their nominal orbit, the convergence time (in the order of 10 $\mu$ s or less, depending on perturbation amplitude) scales with the IBFB latency.

## Dumping of Not Corrected Bunches

The IBFB as well as other beam based feedback systems in E-XFEL like the longitudinal/LLRF feedback may need a number of bunches at the head of the bunch train before their corrections become fully effective and reach the desired stability level. The unstable bunches at the head of the train can be dumped by the beam distribution system upstream of the SASE undulators, so that only stabilized bunches reach the undulators. Due to a maximum bunch train length of 600 $\mu$ s, dumping bunches at the head of the train for a duration of ~10 $\mu$ s has little impact on the achievable average X-ray flux.

## IBFB System Layout

Figure 1 shows the location and topology of the IBFB. The main IBFB components are located just after the collimator, upstream of the beam distribution system and its dump kicker.

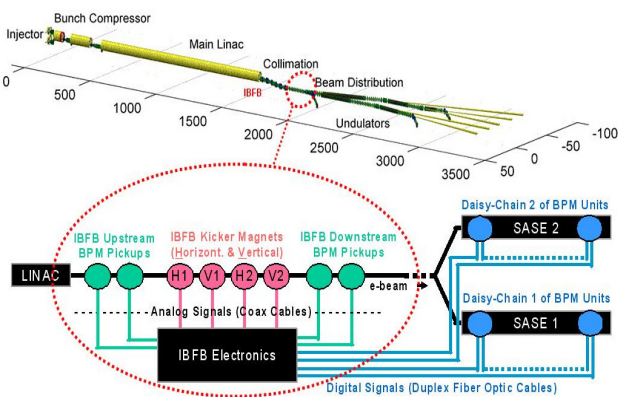

Figure 1: IBFB System Topology.

## IBFB Operation Modes

The IBFB allows to correct the beam position and angle individually for each bunch, using two stripline kickers

for each transverse plane. In the standard operation mode of the IBFB, two adjacent BPMs downstream of the kickers (“downstream BPMs”) send their position data via multi-gigabit fiber optic links to an FPGA signal processing board (originally named “PDC” = PSI DSP Carrier [2]) that performs the feedback and feed-forward algorithms. The PDC calculates the kick angles, using a mezzanine with fast (>500MSPS) DACs to directly generate the stripline kicker signal waveforms via FPGA-based direct digital synthesis (DDS). The DAC signals are amplified via kW-range solid state low-latency RF power amplifiers that drive the stripline kickers.

Two BPMs upstream of the kickers (“upstream BPMs”) are used to monitor if the obtained kick angle has the desired value, by comparing the predicted beam position at the downstream BPMs with the measured one for each bunch. This allows e.g. detection of IBFB system failures, or in-situ calibration and correction of nonlinearities and gain drift of the RF power amplifiers.

In addition to the above described standard operation mode, the IBFB can be operated in an alternative mode where the upstream BPMs instead of the downstream BPMs are used for the fast feedback loop. This mode employs a model-based prediction of the necessary correction kicks, where a comparison of expected and measured beam position at the downstream BPMs allows to correct and adapt the model in real-time.

Compared to the standard mode, the alternative mode reduces the feedback loop latency, and also the noise that the IBFB adds to the beam, since this noise is not seen and coupled back by the BPMs into the feedback loop because they are upstream of the kickers.

However, for reasons of simplicity and robustness, and due to moderate latency requirements and good BPM noise levels of our present BPM prototypes, we favour the standard mode for commissioning and first operation of the E-XFEL and IBFB, where changes of energy and optics that would affect the model and beam response matrix may occur more frequently during tuning and tests of the accelerator and its subsystems.

## Integration of Undulator BPMs

In order to be able to correct perturbations that occur between the IBFB and the undulators, the IBFB also receives the data of all undulator BPMs via multi-gigabit fiber optic links, where the BPMs of each undulator are connected in a bidirectional daisy chain.

For correction of non-reproducible perturbations between IBFB and undulators, at least two undulator BPMs will be equipped with the low-latency electronics, since the latency requirement for the standard BPM electronics is only <10ms. Due to a distance of several 100m between IBFB and undulators, the latency of the undulator BPM data received by the IBFB is several  $\mu$ s.

The E-XFEL beam distribution system [3] has a fast dump kicker that can generate arbitrary bunch patterns for the undulators. This kicker also dumps the beam while a slower but stronger kicker (based on a Lambertson septum and a flat top pulser kicker) changes its field to

redirect part of a bunch train to another undulator [3]. Due to this concept, the high-frequent trajectory perturbations generated by the distribution system should be negligible. Its low-frequent perturbations e.g. due to capacitor bank droop, are minimized by suitable design techniques and are expected to be mainly reproducible.

Therefore, the only expected source of significant non-reproducible perturbations between IBFB and undulators are mechanical magnet vibrations that have low frequencies (typ. 10-100Hz), with a perturbation amplitude that should be low compared to main linac quadrupole vibrations. Thus, the higher latency of the undulator BPM data is uncritical: For the first bunches in a train, the IBFB will only use the downstream (and/or upstream) BPM data to correct the trajectory, in addition to the previously mentioned feed-forward corrections. As soon as the IBFB receives the first readings from the undulator BPMs, it performs additional fine tuning of the beam trajectory so that the following bunches should reach the desired position in the undulators.

*Beam Optics, Magnet Lattice and BPM Locations*

Figure 2 shows the magnet lattice and beam optics in the area of the IBFB. The end of the collimator is near  $s=0$ . The two vertical IBFB kickers are located at  $s=27$  and  $s=57$ m, the horizontal ones at  $s=38$ m and  $s=68$ m. IBFB Kickers and BPMs were placed at locations with large beta functions, and the betatron phases between two kickers and two upstream and downstream BPMs were each optimized to be as close as possible to an odd integer multiple of  $90^\circ$  within the given optics and lattice design constraints. This maximizes the resolution of the BPMs and thus minimizes the BPM-dominated noise that the IBFB adds to the beam.

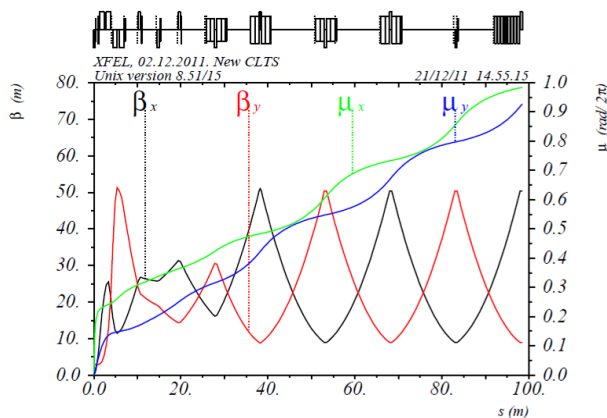

Figure 2: Beta Functions and Betatron Phase in IBFB Area.

Moreover, the optimized kicker locations minimize the RF amplifier power necessary to correct a given perturbation, thus reducing amplifier costs and maximizing the mean time between failures (MTBF) of the amplifiers that improves with lower power.

**IBFB SUBSYSTEMS**

In the following, the concept and design status of the different IBFB subsystems will be reported.

*BPMs*

The E-XFEL uses button as well as some re-entrant single resonator cavity BPMs in the cold linac, and button and dual-resonator cavity BPMs in the warm part of the accelerator [5]. The cost-efficient buttons are used where their resolution is sufficient, while cavities are used where higher resolution is required, e.g. in the E-XFEL undulators.

IBFB upstream and downstream BPMs have the same 40.5mm aperture 3.3GHz cavity BPM pickups [6] as the non-IBFB BPMs elsewhere in the accelerator. However, the requirements for the BPMs used by the fast IBFB feedback loop are more demanding than for the other BPMs. On one hand, the IBFB should have a BPM system latency of a few 100ns, while a latency of  $<10$ ms is sufficient for non-IBFB BPMs that are used e.g. for slow global feedbacks or beam based alignment.

Moreover, noise of the single-bunch position measurements of the IBFB BPMs will be added to the beam by the feedback loop, with a gain depending on IBFB algorithm, feedback loop parameter settings etc. Thus, IBFB BPMs should ideally have sub-micron noise for single-bunch position measurements over the whole bunch charge range. In contrast, non-IBFB applications, e.g. beam-based alignment of undulator quadrupoles and BPMs where sub-micron resolution is also needed, can use the average position of all bunches in a train, where the alignment can be performed at high bunch charge where the BPMs have their best resolution.

The present prototype version of the standard cavity BPM electronics provides sub-micron resolution, where beam tests with three cavity BPMs showed e.g. 120nm RMS at 350pC and 180nm at 183pC bunch charge [7], with an electronics latency of  $\sim 400$ ns (including calculation of beam position in an FPGA).

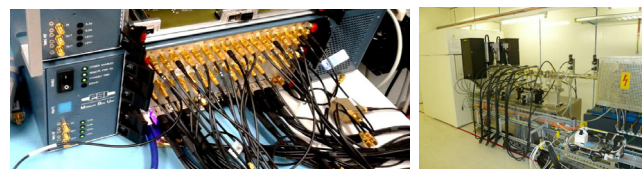

Figure 3: Left: E-XFEL cavity BPM electronics prototype (standalone unit for two cavity BPMs). Right: Cavity BPM pickup test area at SwissFEL Injector Test Facility, with three E-XFEL undulator cavity BPMs and one IBFB cavity BPM.

Although these results were obtained by correlating beam measurements of three adjacent 10mm aperture undulator BPM cavity pickups, the performance for the 40.5mm aperture IBFB upstream and downstream BPM cavity pickup (to be tested in the near future) should be similar, since its sensitivity (in units of V/mm/nC) is only



~20% lower and since 10mm and 40.5mm version have the same loaded Q (~70) and frequency (3.3GHz).

Due to the different requirements for standard and IBFB BPM electronics, we had originally intended to develop a dedicated electronics version for the IBFB BPMs. However, the low latency and good resolution that we achieved with the standard BPM electronics motivates to have a common design for IBFB and non-IBFB BPMs. Therefore the next undulator BPM electronics prototype version will have improvements beneficial for the IBFB, e.g. programmable attenuators for the pickup signals at the RFFE inputs, with >60dB range and 0.5dB steps, compared to four attenuator/charge ranges with ~6dB steps for the present RFFE version. The new RFFE will thus have a significantly reduced dependence of the resolution on the bunch charge compared to the present electronics, where the ADC noise at the lower end of each charge range deteriorates the resolution since less than 50% of the ADC full scale range is used at these charges.

However, lab and beam tests will have to show if we can use the new version for all cavity BPMs in E-XFEL, including IBFB, or if we still need to develop a dedicated IBFB version, e.g. due to the fact that the largest possible signal level of the IBFB pickup is 50V, while a desired resolution and drift of 1µm at a desired lowest bunch charge of 20pC corresponds to a signal level of 50µV, which makes the design of the input stage of the RFFE rather challenging.

*Signal Processing Electronics and Algorithms*

During the preparatory phase of the E-XFEL, starting 2005, we had already developed a prototype for an IBFB signal processing board, consisting of an FPGA Carrier Board (PDC = PSI DSP Carrier) with two mezzanines that each have four 12-bit 500MSPS ADCs and two 16-bit 1GSPS DACs. While we intend to keep the general concept of the PDC board for the final IBFB version, we are currently developing a new carrier board [8] for which we use Xilinx Artix-7 and Kintex-7 (28nm silicon structure size) instead of Virtex-4 (90nm) FPGAs, with a new DSP that is available with one or multiple cores and 20 GFLOPS per core, compared to 3+3 GFLOPS for the DSPs on the previous PDC board version.

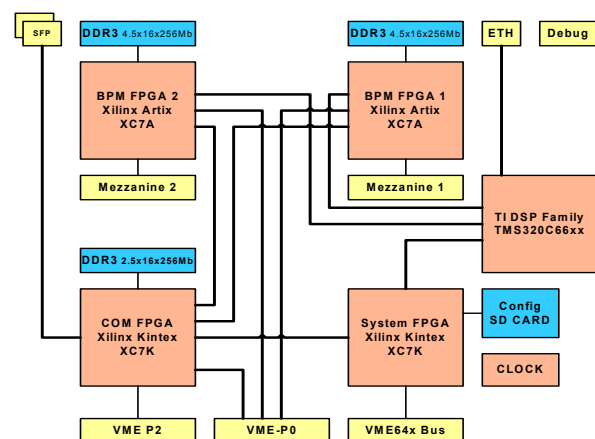

Figure 4: Block Schematics of new FPGA Carrier Board.

Figure 4 shows the simplified block schematics of the new board. For the data transfer between FPGAs, DSPs and high-speed IO connectors (new VME-P0 with >6Gbps/pin, SFP, mezzanines) we use mainly serial multi-gigabit links (5-10Gbps). The board also has multiple parallel LVDS high-speed (~1Gbps) lines to two mezzanines, for interfacing up to six parallel 16-bit ADCs or DACs per mezzanine to so-called “BPM” FPGAs on the mainboard. The “COM” FPGA has single-ended IOs to the VME-P2 connector for slower (<100Mbps) control and status signals from RFFEs or kicker amplifiers. 10G Ethernet is supported via SFP transceivers and VME-P0.

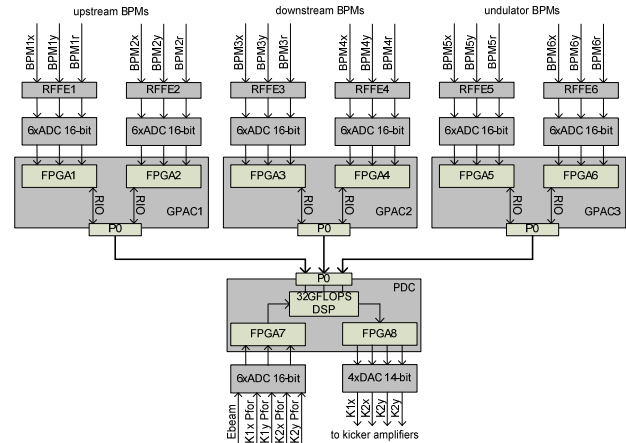

Figure 5: IBFB Electronics / FPGA Board Topology.

By replacing the parallel DSP address/data bus of the previous carrier board version with a few serial multi-gigabit links (using PCIe and SerialRapid IO), the complexity of the layout and thus the board price is massively reduced. Therefore the new board may not only be used as signal processing board for the IBFB algorithms, but also as successor of our present “GPAC” (generic PSI ADC Carrier) board that serves as digital back-end for the present E-XFEL BPM prototypes.

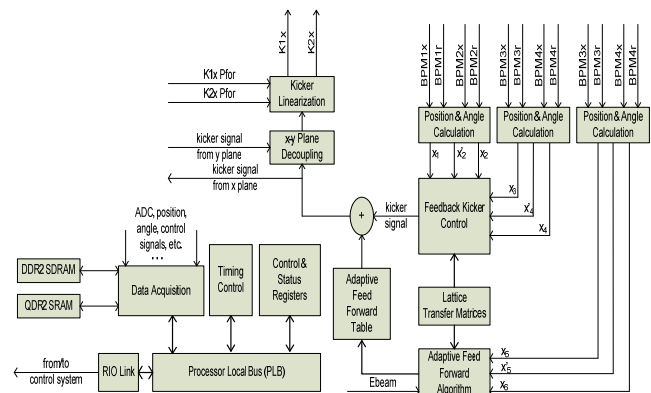

Figure 6: IBFB Feedback/Feedforward FPGA Firmware Block Schematics.

For the IBFB BPMs, we plan to use the same 6-channel 16-bit ADC mezzanine as for the standard cavity BPMs. For control of the kickers, a new DAC mezzanine with 4 channels, 16 bit resolution and >500MSPS sample rate for FPGA-based direct digital synthesis (DDC) of the kicker

waveforms will be developed. Figure 5 shows the hardware layout and interconnections of the IBFB electronics. Figure 6 contains the block schematics of the feedback/feed-forward algorithm to be implemented on the IBFB FPGA carrier board.

### Kicker Magnets

During the E-XFEL preparatory phase [2], 1m long stripline kicker prototypes have been developed [9]. For the final IBFB system, we are currently designing 2m long versions. The main differences of the new version to the previous one – in addition to the length - are the more robust mechanical construction that avoids sensitive ceramic spacers to hold the strips, as well as tapered RF ports to minimize VSWR. In order to get an effective kicker length of 4m for each of the two IBFB kickers per plane, we intend to chain two 2m kickers via RF cables, with a quadrupole in between them. The resulting overall kicker length of 4m allows to reduce the amplifier RF power, thus further improving MTBF and minimizing costs. An RF design and a conceptual mechanical design for the new kicker have already been made (see Figure 7). The detailed construction and production of a prototype is scheduled for the next months.

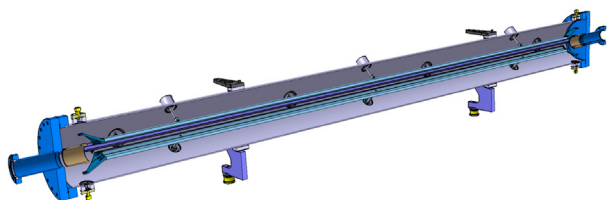

Figure 7: Latest IBFB Kicker Magnet Design (L=2m).

### RF Power Amplifiers

The IBFB kickers will be driven by commercial pulsed solid-state RF power amplifiers, where two amplifiers drive opposite striplines of each kicker in push-pull mode. We recently ordered prototypes with a saturated power of 3kW and a linear power (1dB compression) of 2kW. More than  $\pm 8\mu\text{rad}$  kick angle at 3kW provides ample safety margin with respect to the estimated perturbations (see Table 1), allowing to operate the amplifier well below the saturation point in its linear regime. Any remaining nonlinearities will be calibrated and corrected digitally by the IBFB FPGA board.

The RF power amplifier is based on an off-the-shelf version (shown in Figure 8) but is currently being improved for PSI, e.g. by adding redundant primary (AC/DC) power supplies and redundant RF amplifier modules in order to improve MTBF, and by using newer as well as more robust RF components that tolerate 100% reflection at the amplifier output at full power. The maximum pulse length is 1ms, with up to 3% duty cycle and <50ns latency (input to output). A bandwidth of at least 10-100MHz will allow to use DC-free sinusoidal or rectangular amplitude-modulated waveforms up to some 10MHz frequency to drive the kickers. The signal frequency (integer multiple of the bunch rep. rate), phase

and chain cable length for the 2m elements is chosen so that the beam sees just the positive (or negative) half waves of the stripline signals when passing the kickers. It should be noted that, despite a lower amplifier bandwidth of ~10MHz, the kickers can correct orbit perturbations down to DC: The kicker waveform is DC-free, but the bunches just see a fraction of the waveform that is not DC-free and thus can be corrected down to DC.

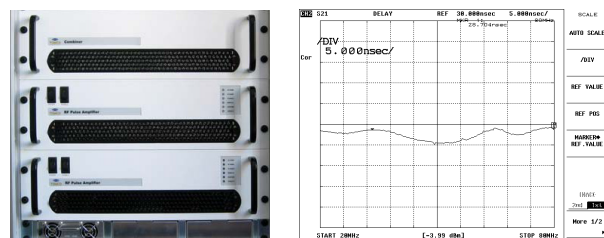

Figure 8: Left: Prototype RF power amplifier, similar to the dedicated IBFB version that is in production (4kW, 5-175MHz BW, <30ns latency). Right: Amplifier latency measurement (courtesy TOMCO Technologies, horizontal scale 20-80MHz, vertical scale 5-55ns, latency <30ns).

## STATUS AND OUTLOOK

The development of IBFB concept and subsystems at PSI is progressing from prototypes towards pre-series versions and the final design. We are currently merging initially separate designs for IBFB and general BPM system where possible, aiming at electronics modules that meet the more demanding latency and performance requirements of the IBFB while being cost-effective enough for large-scale use in the E-XFEL BPM system.

The IBFB will use cavity BPMs where beam tests have already demonstrated sub-micron resolution. The next electronics revision that is currently being developed will further minimize BPM-dominated noise added to the beam by the IBFB, using the latest FPGA and DSP technology. For the IBFB kicker system, prototype production and test are planned for 2013, while IBFB beam commissioning is scheduled for autumn 2015.

## REFERENCES

- [1] R. Brinkmann, "The European XFEL Project", Proceedings FEL'06, Berlin, Germany, 2006.
- [2] B. Keil et al., "Design of an Intra Bunch Train Feedback System For The European XFEL", Proceedings DIPAC'07, p. 232.
- [3] W. Decking et al., "Layout of the Beam Switchyard at the European XFEL", Proceedings EPAC'08, p. 2163.
- [4] W. Decking, private communications.
- [5] B. Keil et al., "The European XFEL Beam Position Monitor System", Proceedings IPAC'10, p. 1125.
- [6] D. Lipka et al., "Development of Cavity BPM for the European XFEL", Proceedings Linac'10, p. 631.
- [7] M. Stadler et al., "Beam Test Results of Undulator Cavity BPM Electronics For European XFEL", these proceedings.
- [8] B. Keil et al., "A Generic BPM Electronics Platform for European XFEL, SwissFEL and SLS", these proceedings.
- [9] M. Dehler et al., "Stripline Devices for FLASH and European XFEL", Proceedings BIW'08, p. 114.