

FIRST TESTS OF A LOW CHARGE MTCA-BASED ELECTRONICS FOR BUTTON AND STRIP-LINE BPM AT FLASH

B. Lorbeer*, N. Baboi, F. Schmidt-Föhre, Deutsches Elektronen-Synchrotron[†], Hamburg, Germany

Abstract

Current FEL based light sources foresee operation with very short electron bunches. These can be obtained with charges of 100pC and lower. The typical charge range for FLASH, DESY, Hamburg spans a range from 100pC up to 1nC. The electronics currently installed at button and strip-line BPMs have been designed for best performance at higher charges and have reached their limits. Currently, for low charges a new type of electronics is being developed to overcome these limitations. These electronics are conforming with the MTCA.4 for physics standard [1]. The next generation of FLASH BPM electronics is suitable for measurements of button and strip-line BPMs. Furthermore, the first measurement results taken with beam at FLASH, DESY are presented here.

INTRODUCTION

Free-electron-laser (FEL) user facilities like FLASH at DESY and LCLS at SLAC have been established as very useful sources in the VUV and X-Ray regime. Apart from the laser-like features of these sources, the short light pulses produced by these machines are very attractive for users. Recently it turned out that the typical pulse length of about 100fs can be shortened substantially. The operation of these FEL facilities have demonstrated that beam charges smaller than 100pC allow the generation of very short electron bunches resulting in FEL pulse lengths in the few fs regime [2, 3]. Since existing electronics for button and strip-line beam position monitors (BPM) of FLASH have been designed for a charge of about 1 nC, they show insufficient resolution for machine operation below 300pC. Therefore, a new type of button and strip-line electronics is under development. The dynamic range has been extended to lower charges to match the increasing need for low charge operation. At FLASH the Micro Telecommunication Computing Architecture (MTCA) for physics standard will replace the old Versa Module Eurocard (VME) based electronics of the old BPM system. The standard introduces a new environment for the analog front-end and digitizer electronics. The specifications for the new FLASH BPM electronics match with the ones from European XFEL [4]. The requirement for single-bunch resolution is 50μm in an aperture of +/- 3mm of center with a beam line diameter of 40mm [5]. In this paper the first prototype BPM electronic system based on the MTCA.4 standard is introduced. The analog electronics are described in detail. The first measurements with single-bunch operation are presented.

* bastian.lorbeer@desy.de

[†] DESY

OVERVIEW

The MTCA-based button and strip-line BPM system is schematically shown in Fig. 1.

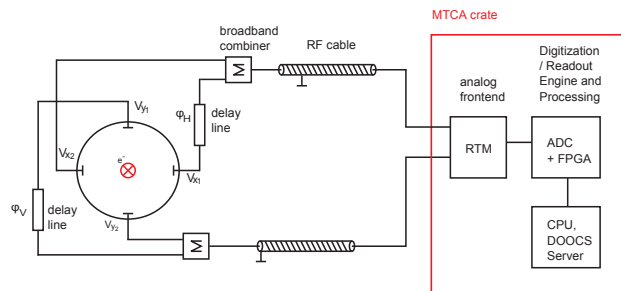

Figure 1: BPM conceptual system setup. One signal of each plane from the BPM is combined with the other after a delay of ca. 100ns. The combined signals are then transported over a long RF cable from the tunnel to the electronic racks.

It follows the well-known Delay Multiplex Single Path Technology (DMSPT), originally developed in 1986 for the HERA accelerator at DESY[6]. The pick-ups of the button and strip-line BPMs are oriented in the vertical and horizontal plane in the beam line. The strip-line monitor under test is the main type of standard BPM currently in operation at FLASH. The beam line diameter is 34mm and the strip-line length is 200mm. The button monitor used here is a prototype button BPM for the E-XFEL. It is an improved HERA type button pick-up design to match the needs in linear machines such as FLASH, and the E-XFEL. The button diameter is 16mm and the beam line diameter is 34mm. It has been installed and studied in the last year at FLASH [7]. The signals V_{x1} and V_{x2} in the horizontal, and V_{y1} and V_{y2} in the vertical plane are concatenated with the help of a broadband radio frequency (RF) combiner. This is done by inserting a delay of 100ns for V_{x1} and V_{y1} with respect to the other signal in each plane. Finally the signals are travelling on a 80 m long 3/8" RF-cable from a patch panel in the tunnel to a patch panel at an electronic rack outside the tunnel. This method has a superior common mode electromagnetic interference (EMI) rejection compared to a single RF cable connection for both signals in each plane. Typical signals from a button and a strip-line monitor are shown in Fig. 2. A zoom of the signals is shown in Fig 3.

The rise-time of both signals is in the order of a few hundred picoseconds. Though the signal shape for both types of BPM is entirely different, the front-end can measure both types of waveforms. With a beam charge of 100pC and a centered beam the signal strength is 180mV_{peak} for the strip-line and 270mV_{peak} for the button BPM. The

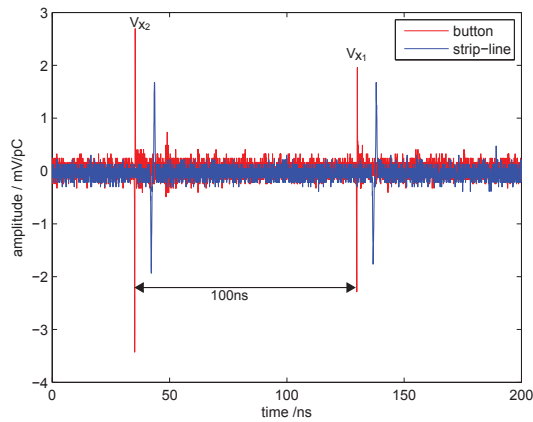

Figure 2: Button and strip-line monitor signals measured in electronic racks. The amplitude is normalized to pC.

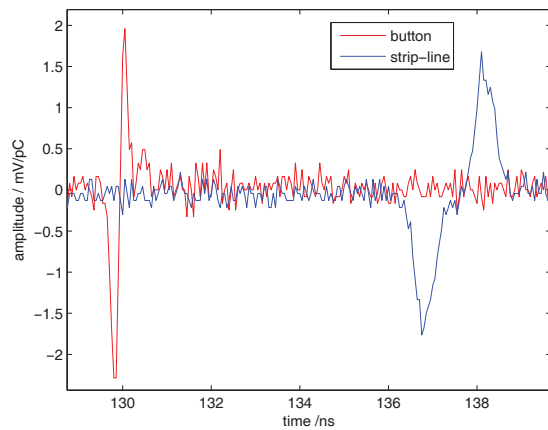

Figure 3: A zoom of the strip-line and button BPM.

acquisition takes place on an analog front-end module, a digitizer with a generic FPGA firmware, and a CPU module. All boards are designed to be compatible with the MTCA.4 standard. The analog front-end on a rear transition module (RTM), the digitizer on double size advanced mezzanine card (AMC), and the MTCA crate will be described in more detail in this paper.

ANALOG FRONT-END

The signals from either button or strip-line BPM are received by an analog front-end. A picture of the prototype board is shown in Fig. 4.

The standard size for a MTCA.4 compatible RTM is 180mm x 162mm. The module is powered by a single +12V supply. Other voltages are generated by DC/DC converters and voltage regulators. The connector on the right-hand side of the picture is the so called Zone3 connector. It carries the interface to the Advanced Mezzanine Card (AMC) digitizer card. A single receiver consists of two channels. Each channel measures one plane of a BPM. The

ISBN 978-3-95450-119-9

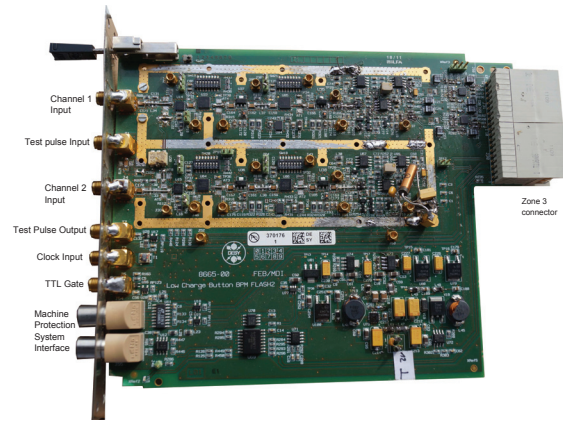

Figure 4: The prototype electronics for one BPM are located on a standard MTCA.4 for physics rear transition module.

receiver for each plane is based on a peak detector that is driven by an alternating cascade of a low noise amplifier and a digital step attenuator. The step attenuator can be adjusted over a wide range from 0...31.25dB in steps of 0.25dB. The maximum small signal gain of the front-end is in the order of 40dB. The block diagram of one channel is shown in Fig. 5.

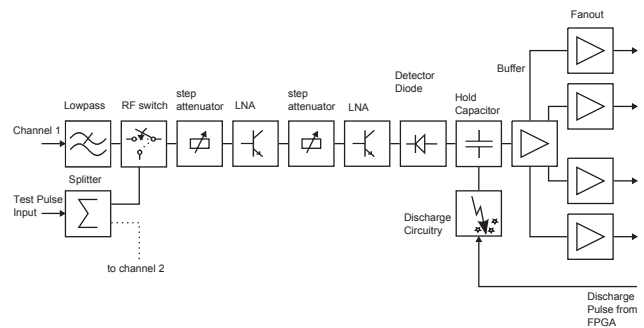

Figure 5: Block diagram of the front-end for the position measurement in one plane.

The purpose of the first step attenuator in the measurement chain of each plane is to adjust the power level for the different beam charges, while the second step attenuator optimizes the signal level for the different transverse offset's. The output of the second amplifier drives a fast detector composed of a Schottky diode and a peak hold capacitor. The hold capacitor is actively discharged with a fast discharge circuitry. The discharge circuit is driven by an external pulse generator that is synchronized with the machine timing. The hold capacitor is followed by a buffer operation amplifier and a fanout with four outputs. This fanout offers the opportunity to sample in an inter-leaved mode and hereby increasing the number of sample-points per waveform, resulting in an improved resolution. An additional feature of the front-end is the possibility for inter macro pulse calibration of the electronics using either an external pulse or a pulse signal sent from a field pro-

programmable gate array (FPGA) on the digitizer AMC. In calibration mode the RF switch is switched to calibration mode. Moreover the front-end board has an interlock interface to the Machine Protection System and an I2C bus interface for optional purposes. In the AC coupled part of the front-end the lower cut-off frequency is <5MHz and the upper bandwidth limit is at the -3dB point is 350MHz. After the peak detector the signal path is DC-coupled and the bandwidth is <160MHz at the fanout. The measured noise figure from input jack to the input of the detector diode is <7dB. In order to have a sufficient drive voltage on the peak detector the minimum input peak voltage is 20mV. The strip-line and button BPM types tested with this new electronic deliver a sufficient signal strength to measure the position at charges down to 30pC.

MTCA CRATE

For the test measurements a five slot MTCA from Schroff has been used (Fig. 6).



Figure 6: Crate used for the tests including management carrier hub (MCH), hard disk (HD), processor (CPU), digitizer SIS8300, and timing module x1timer. The BPM front-end RTM is on the rear side and is not shown here.

The analog signals from the RTM are digitized on a commercially available 10 channel digitizer SIS8300 [8]. After the digitization the raw data is collected on a control system server that is running on the crate CPU. The server is read out by a Matlab program running on a remote PC via ethernet. The beam offset is calculated here. The synchronization of the measured data is done with a timing module x1timer. The x1timer receives a 108MHz clock signal from the master oscillator and a machine trigger from the old VME based timing system. The x1timer redistributes the trigger and clock to the digitizer card to clock and trigger ADC's and FPGA. At the moment a generic FPGA firmware has been used to obtain the raw data sample points from the ADC's. The development of a custom made firmware is under way.

Position Calculation

The expressions to calculate the beam offset positions in the horizontal and vertical plane are given by Eq. (1) and Eq. (2):

$$x_{\text{offset}} \sim \frac{V_{x_1} - V_{x_2}}{V_{x_1} + V_{x_2}} = \frac{\Delta_x}{\Sigma_x} \quad (1)$$

$$y_{\text{offset}} \sim \frac{V_{y_1} - V_{y_2}}{V_{y_1} + V_{y_2}} = \frac{\Delta_y}{\Sigma_y} \quad (2)$$

The values of the Δ/Σ - term is normalized to the charge. They lie in the range between +1 and -1. The proportionality factor in Equ. (1) and (2) is mainly given by beam line diameter, button size or strip-line length. The factor has been obtained from electromagnetic field simulation of a beam excited structure considering the entire geometry or can be obtained experimentally from calibration of the monitor in the machine. At the point of the maximum slope, where the sign of the Δ/Σ - term flips the monitor constant k is defined. From simulations we obtain $k_{\text{strip}} = 19.8\text{mm}$ for the strip-line monitor and from a combination of simulations and measurements we obtain $k_{\text{button}} = 12.3\text{mm}$ for the button BPM [7].

MEASUREMENT DATA

During recent beam studies it was possible to make position sweeps for typical button and strip-line BPM using the new electronic system in a MTCA crate. A typical raw data trace from hundred subsequent measurements for a strip-line BPM is shown in Fig. 7.

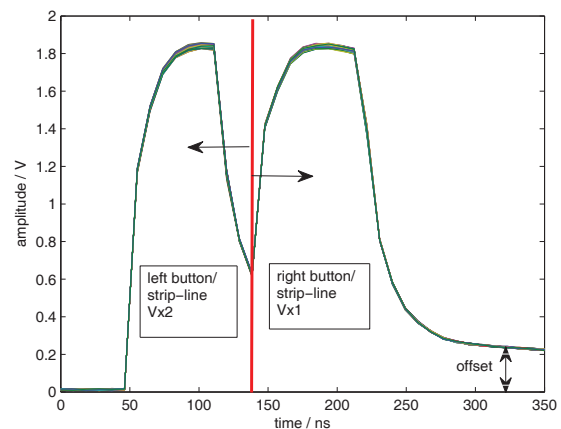

Figure 7: Raw data for a centered beam measured at 500pC for the strip-line monitor. The sampling time step is 9.23ns. The data is taken for 100 subsequent pulses in single-bunch mode.

The graph shows the ADC data for hundred subsequent macro-pulses in single-bunch mode. The same signal strengths for V_{x_1} and V_{x_2} indicate that the beam is centered. The fluctuations in the hundred subsequent measurements originate from the beam jitter as well as from

limitation of the electronic resolution. For the calculation of the Δ/Σ - term only the maxima of V_{x_1} and V_{x_2} have been considered. Consequently, all horizontal offset positions deliver hundred points.

Strip-line Monitor

The strip-line under test is positioned after the first bunch compressor in FLASH. The quadrupoles nearby have been switched off for these measurements in order to have a drift line. With the help of a steering magnet in this section the beam could be moved transversely by approximately ± 3 mm at the position of the strip-line under test. The position sweep detected with the new electronics is shown in Fig. 8. The Δ/Σ is plotted against the steerer current. The charge was approximately 20pC. In the circuit configuration for these measurements the maximum drive level on the detector diode is $1V_{\text{peak}}$ and a minimum of $0.5V_{\text{peak}}$. Using Eq. 1 this leads to a measurable aperture of approximately ± 3.5 mm.

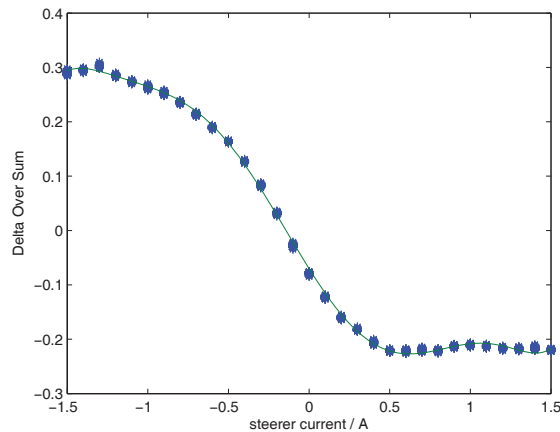

Figure 8: Position sweep at 20pC for the strip-line BPM.

Button Monitor

The button BPM under test is installed in a dump section prior to the undulator section in the FLASH facility. The electron beam has been moved using a dipole magnet. The beam has been detected on a screen at the end of the section. The distance between the BPM and the screen is 0.6m. The measured charge was 80pC. With the calibration constant of the screen the relative movement at the BPM under test could be estimated. The measurable aperture is approximately ± 4 mm with an error of 10%. The position sweep is shown in Fig. 9.

PERFORMANCE ESTIMATION

The resolution for the strip-line and button BPM have been estimated using the monitor constants k_{strip} and k_{button} respectively multiplied by the measured Δ/Σ values. The standard deviation for the strip-line BPM is well below $50\mu\text{m}_{\text{rms}}$ at all offset positions. The measurable

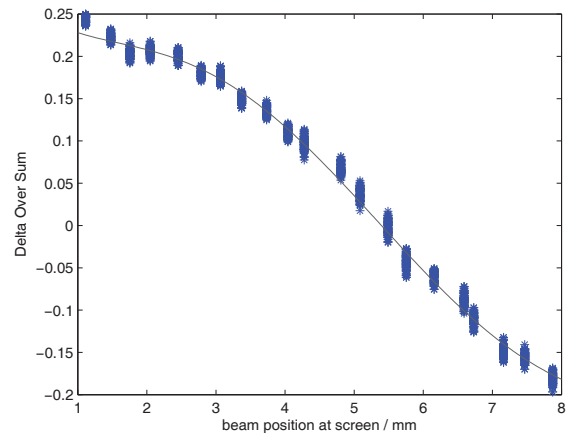

Figure 9: Position sweep at 80pC for the button BPM.

range fulfills the requirements. The expected resolution will improve when considering several points for the position calculation. In the case of the button BPM, the standard deviation at all positions is on the order of $100\mu\text{m}_{\text{rms}}$. The measurement range is larger than required. One possible reason explaining that the resolution is worse than required might be that the dipole transfers the energy jitter into a position jitter. A cure for this is to perform future measurements in a dispersion free section of the machine with the same type of BPM. In order to have a real resolution measurement excluding the beam jitter one needs several BPM systems of this new type. The individual BPM's can then be compared with all other BPM's. Plans to do this in the future are under way.

SUMMARY

The prototype of the first MTCA compatible electronics for button and strip-line BPM has been tested in FLASH. The measurements show promising results for a new type of BPM to be used in the future at FLASH, DESY in Hamburg. The analog electronics have successfully been integrated on a MTCA.4 for physics RTM. The test setup for the strip-line BPM has shown sufficient measurement performance of $50\mu\text{m}_{\text{rms}}$ at charges below 100pC, even in a non optimized readout configuration. The measurement of the button BPM probably includes a huge amount of beam jitter. With a removed beam jitter in a future measurement the resolution will improve significantly.

OUTLOOK

The drive voltage on the detector circuit will be increased in order to obtain higher accuracy, linearity, and an extended measurement range for transverse offsets. A redesign of this prototype is planned for this year. Reference measurements in the laboratory and calibration of the analog front-end are in progress. The readout configuration will be further improved by optimized sample timing, attenuation control, and correction of acquired data.

ACKNOWLEDGMENT

Sincere thanks go to Rudolf Neumann and J.Lund-Nielsen for many discussions, advice, circuit ideas, concerns and inspiration. We also acknowledge the good collaborative work with K.Rehlich and colleagues and the support from the DESY FEB department.

REFERENCES

- [1] PICMG MTCA.4 Revision 1.0, "MicroTCA Enhancements for Rear I/O and Precision Timing", August 22, 2011, <http://www.picmg.com>
- [2] J. Rönsch-Schulenburg et. al., "Generation of ultra-short electron bunches at FLASH", THPD33, Proceedings of FEL2012, Nara, Japan.
- [3] Y.Ding, "Measurements and Simulations of Ultralow Emittance and Ultrashort Electron Beams in the Linac Coherent Light Source", Physical Review Letter 102, 254801 (2009).
- [4] D. Nölle, "The European XFEL Beam Position Monitor System", Conceptual Design Report, Rev.1.00, June 15 2010
- [5] N. Baboi private communication.
- [6] F. Schmidt-Föhre et. al, "BPM system upgrades in the Petra 3 Pre-accelerator chain during the 2008 shutdown", MOPD20, Proceedings of DIPAC09, Basel, Switzerland.
- [7] D. Lipka et. al., "Button BPM Development for the European XFEL", MOPD19, Proceedings of DIPAC2011, Hamburg, Germany.
- [8] SIS8300, "MTCA for Physics digitizer", August 2011, <http://www.struck.de>