

SuperKEKB status and 2025c operation schedule

Gaku Mitsuka (KEK, Accelerator Laboratory)

B2GM, 26 Feb. 2025

Special thanks to K. Shibata, M. Tobiya, K. Trabelsi, S. Uno, K. Uno, F. Miyahara, N. Iida, Y. Ohnishi, Y. Funakoshi, S. Terui, S. Ogasawara, K. Watanabe, Y. Sakaki, T. Ishibashi, H. Sugimoto, R. Ueki, and many others.



Outline

- **Summary of 2024c operation**
- Highlights from Linac operation
- Highlights from MR operation
 - Beam injection & Nonlinear collimator
 - Emittance blowup
 - Beam-beam effects
 - Sudden beam loss events
- Preparation for 2025c operation
- Plan & Summary

Summary of 2024c operation

- **Peak Luminosity**

- $5.1 \times 10^{34} \text{ cm}^{-2}\text{s}^{-1}$ at $\beta_x^* = 60 \text{ mm}$, $\beta_y^* = 1 \text{ mm}$, $I_{\text{LER}} = 1.63 \text{ A}$, $I_{\text{HER}} = 1.26 \text{ A}$, $n_b = 2346$ (note: Belle II HV off)

- **Achievements and findings**

- 2-bunch operation (almost) always in LER, although discharge in the RF-gun cavity at the end of Nov. prevented 2-bunch operation in HER.
- Nonlinear collimator helped reduce storage/injection beam background.
- Squeezing β_x^* mitigates beam-beam-induced horizontal beam blowup in LER.
- Vacuum leak sealant "VACSEAL" was found to be a strong candidate for causing SBL events.

- **Issues**

- Large vertical emittance has remained in 2024c compared with 2022ab and 2024ab
- We observed horizontal tune differences along the bunch train in LER.
 - Tune difference increased as the beam current increased.
 - Injection becomes difficult as the head and/or tail could touch the resonance line.
- Tolerance of vertical orbit at the skew sextupoles was very tight.

Summary of 2024c operation

2024ab (Jan. 29 – Jul. 1, 2024)

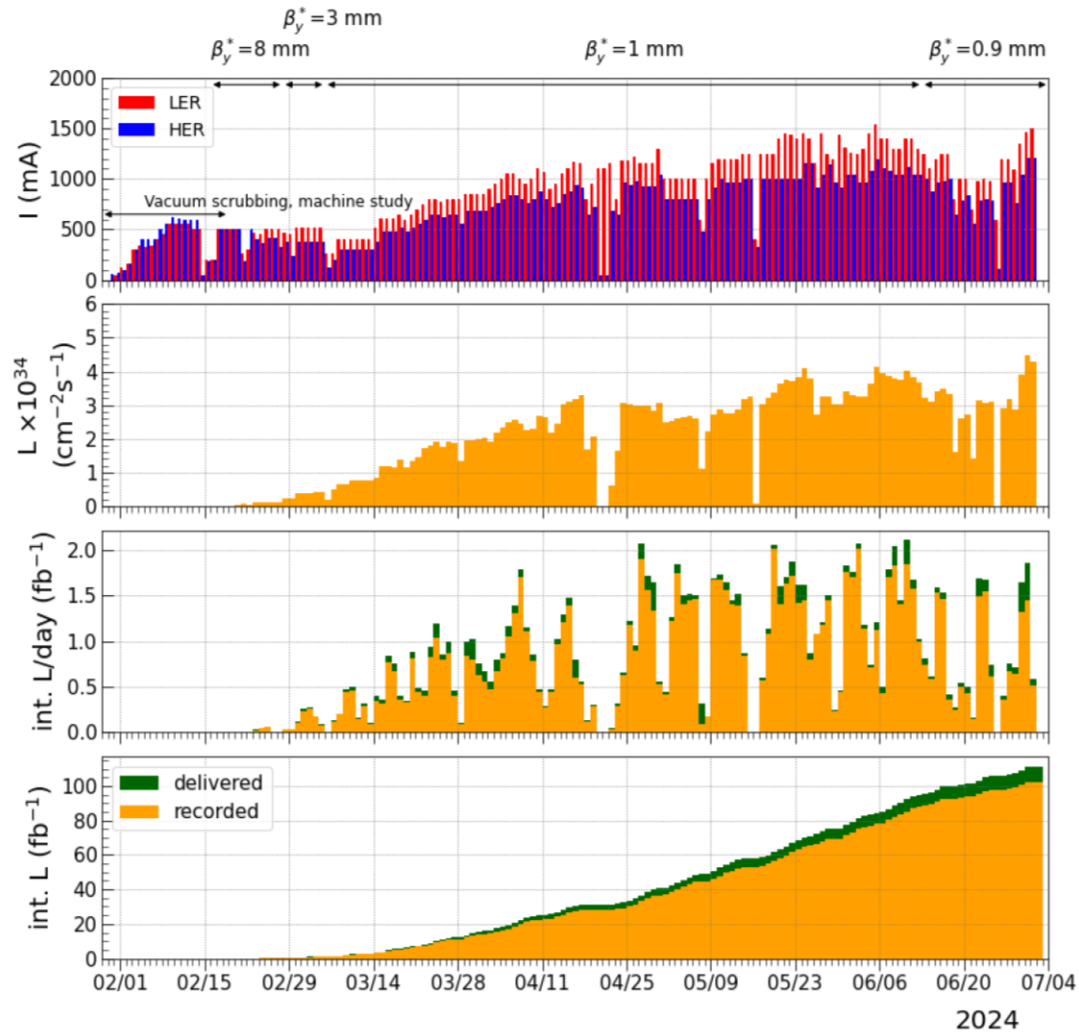

2024c (Oct. 9 - Dec. 27, 2024)

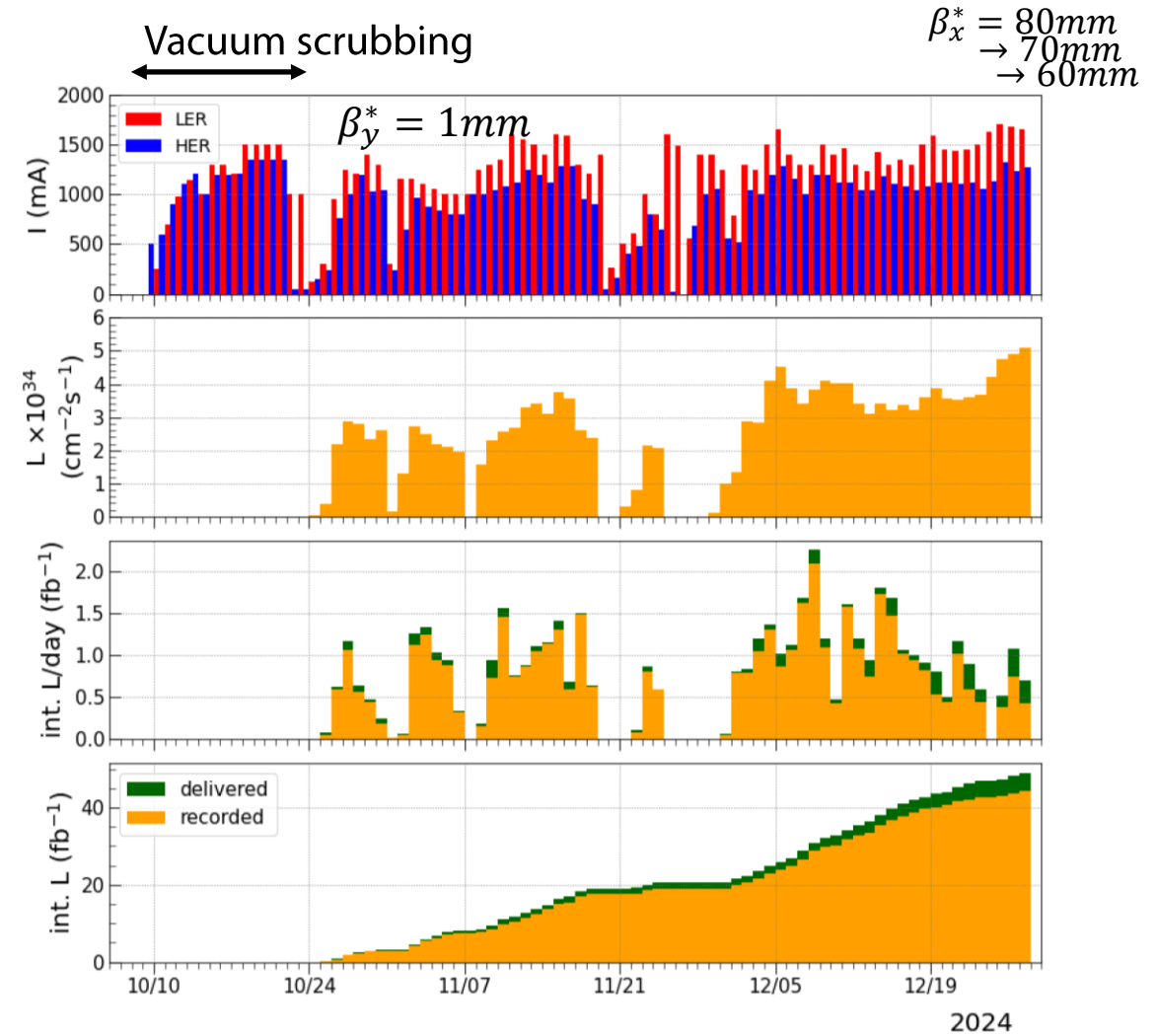

Machine parameters

	December 27, 2024		Target at post-LS1 (1)		Target at post-LS1 (2)		Unit
Ring	LER	HER	LER	HER	LER	HER	
Emittance	4.0	4.6	4.0	4.6	4.0	4.6	nm
Beam Current	1632	1259	2080	1480	2750	2200	mA
Number of bunches	2346		2346		2346		
Bunch current	0.696	0.537	0.89	0.63	1.17	0.94	mA
Horizontal size σ_x^*	15.5	16.6	17.9	16.6	17.9	16.6	μm
Vertical cap sigma Σ_y^*	0.375		0.217		0.178		μm
Vertical size σ_y^*	0.265		0.154		0.126		μm
Betatron tunes ν_x / ν_y	44.525 / 46.589	45.531 / 43.599	44.525 / 46.589	45.532 / 43.573	44.525 / 46.589	45.532 / 43.573	
β_x^* / β_y^*	60 / 1.0	60 / 1.0	80 / 0.8	60 / 0.8	80 / 0.6	60 / 0.6	mm
σ_z	4.6 (6.0*)	5.1 (6.1*)	4.6 (6.5*)	5.1 (6.4*)	4.6 (6.5*)	5.1 (6.4*)	mm
Piwinski angle	12.3	12.7	10.7	12.7	10.7	12.7	
Crab waist ratio	80	60	80	80	80	80	%
Beam-Beam ξ_y	0.036	0.027	0.0444	0.0356	0.0604	0.0431	
Specific luminosity	5.8×10^{31}		7.62×10^{31}		9.31×10^{31}		$\text{cm}^{-2}\text{s}^{-1}/\text{mA}^2$
Luminosity	5.1×10^{34}		1×10^{35}		2.4×10^{35}		$\text{cm}^{-2}\text{s}^{-1}$

* Bunch lengthening is considered by using streak camera measurements.

Outline

- Summary of 2024c operation
- **Highlights from Linac operation**
- Highlights from MR operation
 - Beam injection & Nonlinear collimator
 - Emittance blowup
 - Beam-beam effects
 - Sudden beam loss events
- Preparation for 2025c operation
- Plan & Summary

Summary of Linac operation

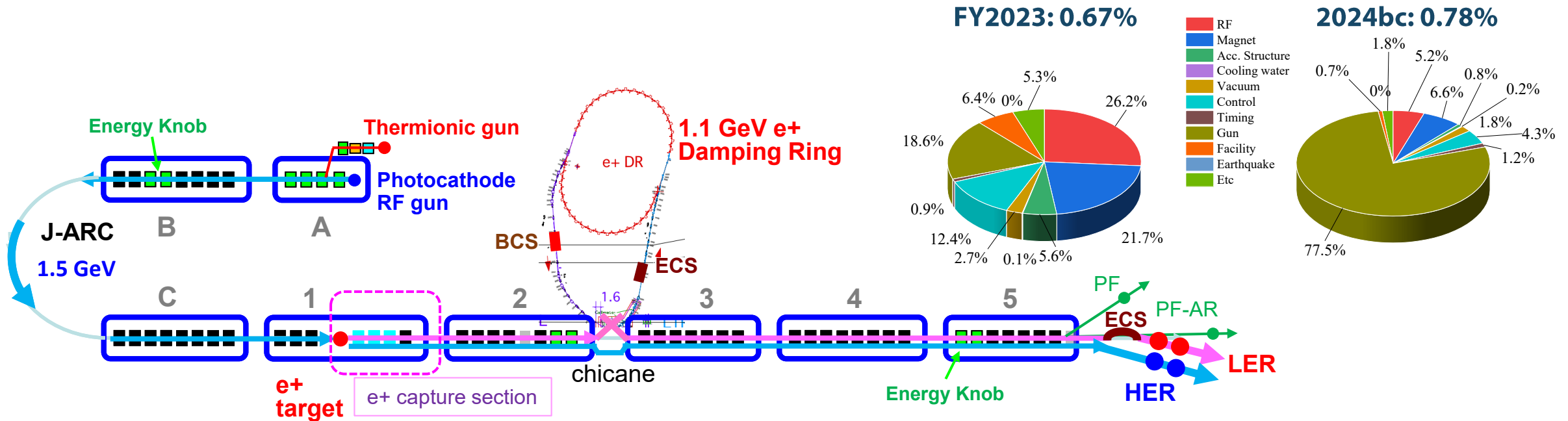

Electron beam

- A beam with 2 nC has been stably delivered to the BT end with bunch charge feedback.
- RF gun's down rate increased since the end of November when severe discharge occurred.
- RF with a pulse length of 1.1 μ s is normally input into the cavity for 2-bunch operation. However, after the discharge damaged the cavity, the pulse length was limited to a maximum of 1 μ s.

Positron beam

- ML-based automatic tuning helped to increase the e+ bunch charge (4.2 nC at the linac end; cf. design goal 4.0 nC)
- DR stored current was limited to 35 mA (radiation safety). The beam current limit will be relaxed in 2025.

Fast kicker for a correction of 2nd bunch orbit

Background

- The 2nd bunch orbit must be same as the 1st bunch to have an equivalent injection efficiency each other.
- 1st and 2nd bunches must pass through the center of accelerating structures to suppress emittance growth.

Solution

- Kicking only the 2nd bunch with fast steering magnets

Status & plan

- Only one fast kicker is for e+ beam correction; no horizontal kicker
- Relocation of SY3 kicker (NG) to 4-sector and install 2+ horizontal kickers

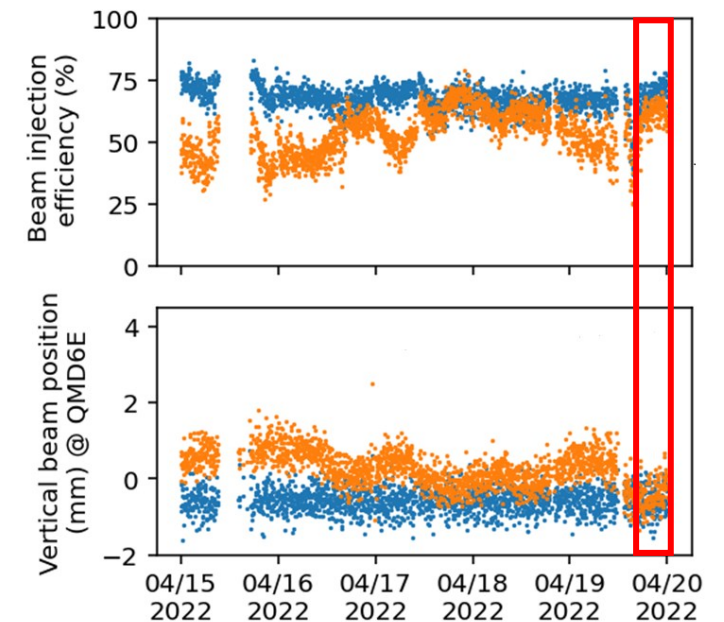
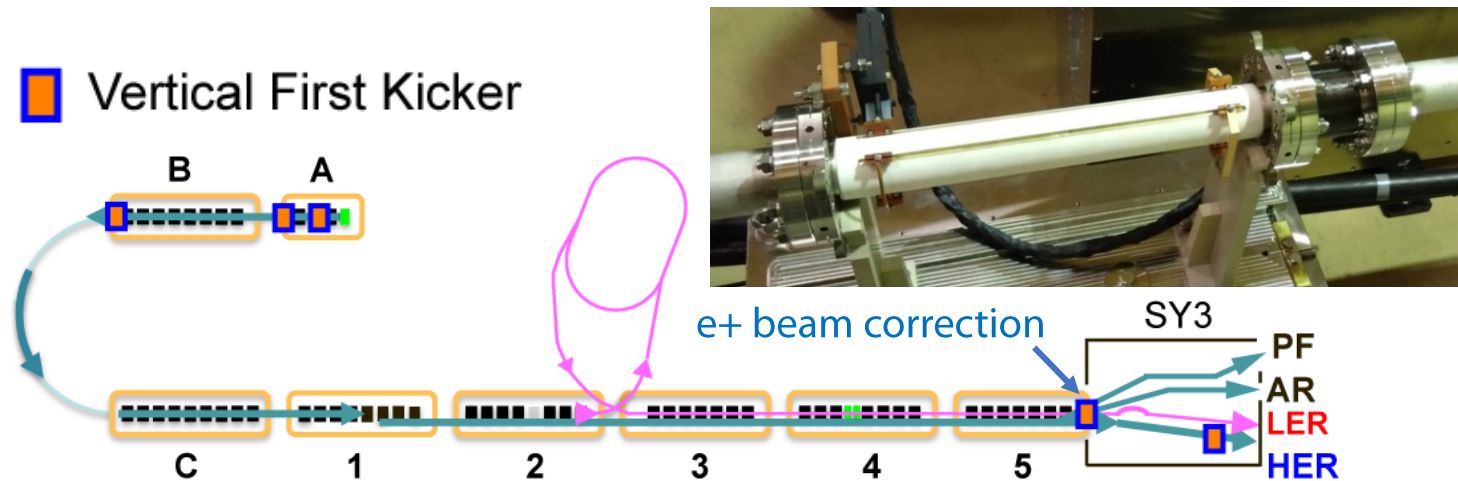

Injection efficiencies and orbit trend of the 1st and 2nd bunches (HER).

Outline

- Summary of 2024c operation
- Highlights from Linac operation
- **Highlights from MR operation**
 - Beam injection & Nonlinear collimator
 - Emittance blowup
 - Beam-beam effects
 - Sudden beam loss events
- Preparation for 2025c operation
- Plan & Summary

Beam injection

Increasing β_x from 100 m to 160 m at the injection point reduces the injection oscillation ($2J_x$) even though ΔX remains.

We expect

- higher injection efficiency,
- lower beam background.

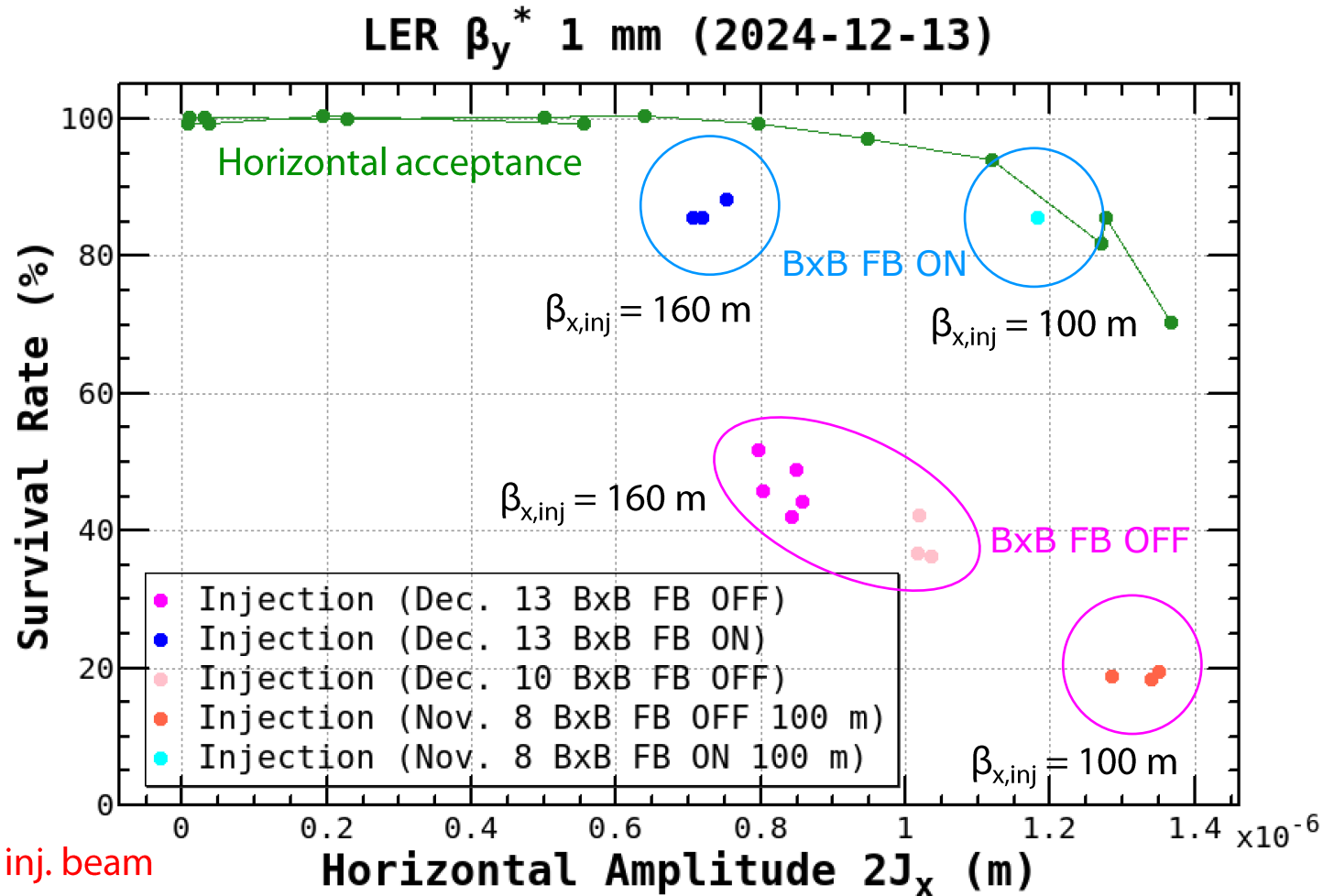
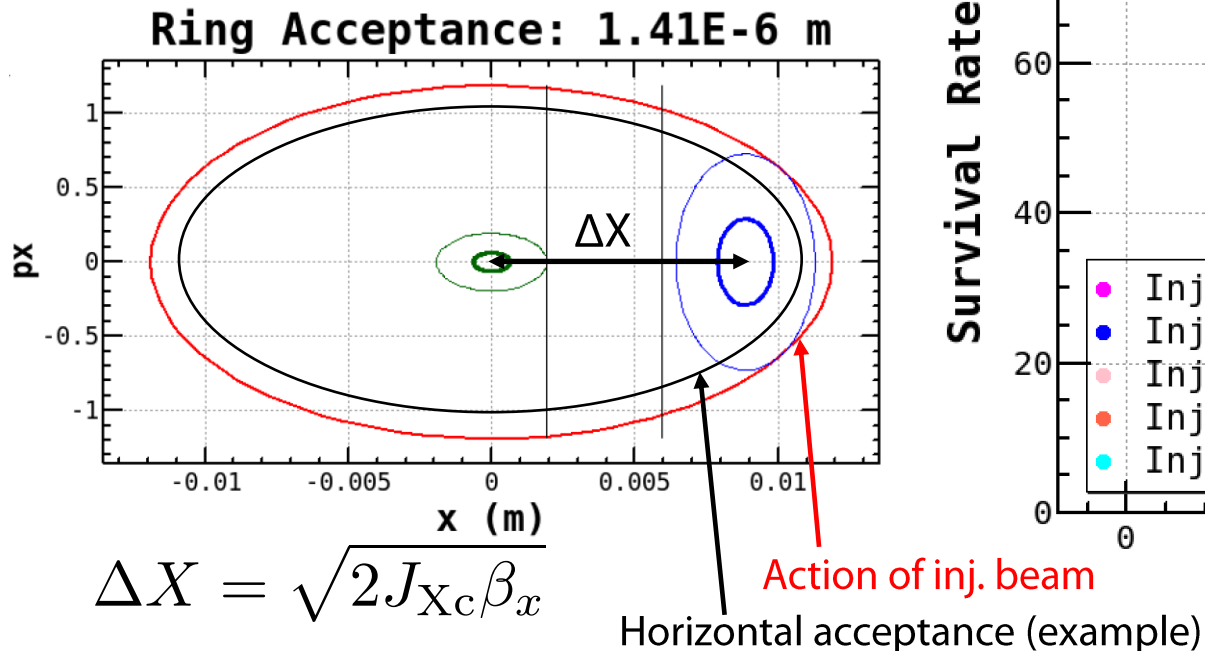

Nonlinear collimator (NLC)

NLC at D05V1 can substitute the conventional collimator at D06V1 to reduce the storage beam background, which leads to less impact on the impedance.

NLC also reduces the injection background by lowering β_x from 7 m to 3 m at the skew sextupole.

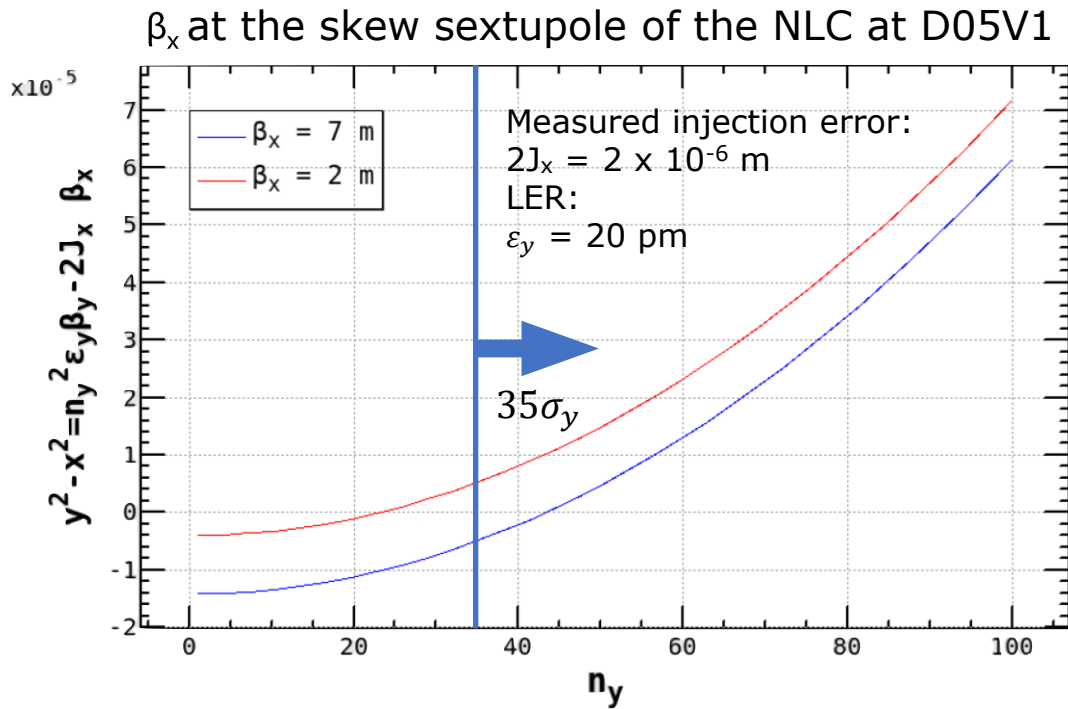

Lower β_x at the skew sextupole is preferable for larger vertical position. $\Delta p_y = \frac{B_x L}{B\rho} = \frac{SK_2}{2} (y^2 - x^2)$

11 Nov. 2024

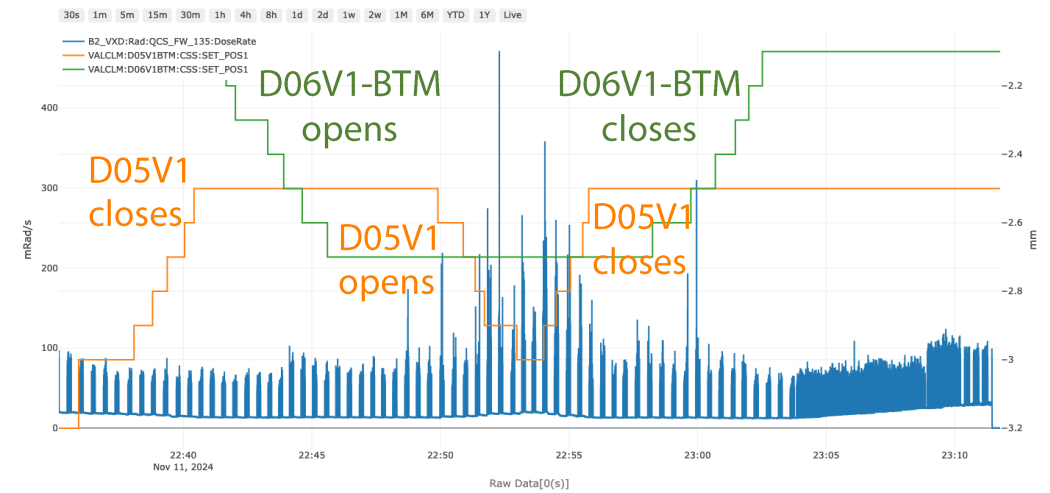

13 Nov. 2024

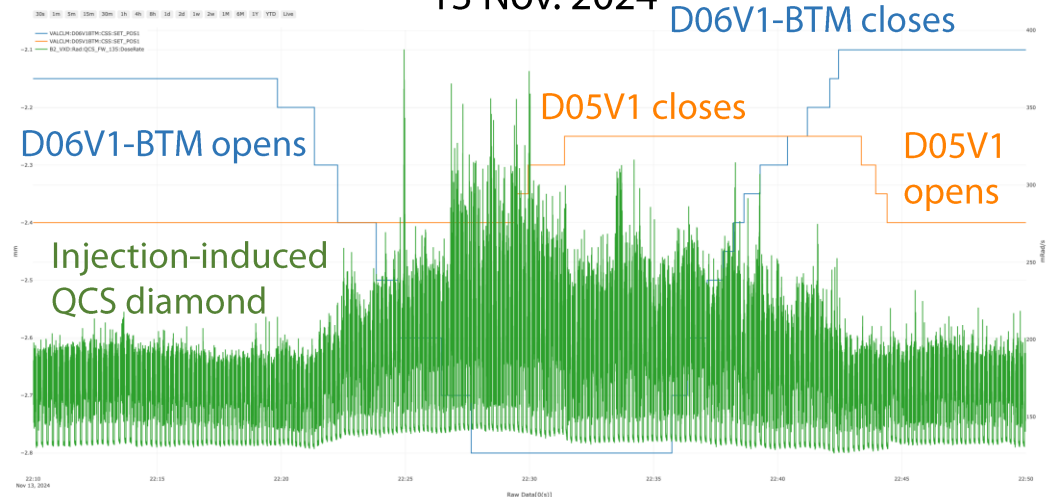

Emittance blowup

- **Vertical emittance after low emittance tuning was $\epsilon_y = 50-80$ pm. (cf. $\epsilon_y \sim 20$ pm in 2024ab.)**
- It seems the problem started at the 2024c startup when vacuum scrubbing was performed.
 - 9 Oct. 2024c startup with detuned optics at $\beta_y^* = 81$ mm
 - $\epsilon_y \sim 20$ pm at 50 mA stored beam current
 - 16 Oct. after NEG activation
 - Optics correction achieved $\epsilon_y \sim 25$ pm.
 - 21-23 Oct. at 50 mA
 - $\epsilon_y \sim 50$ pm before the β_y^* squeezing (no optics correction was performed at that time)
 - $\epsilon_y \sim 70$ pm for $\beta_y^* = 1$ mm optics after optics tuning

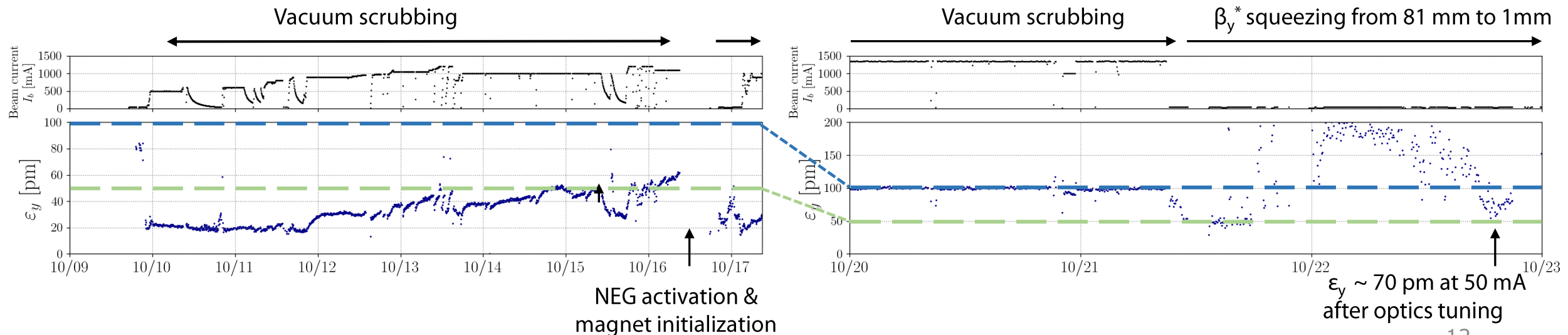

Emittance blowup

Orbit cleaning and smoothing the golden orbit achieved the emittance $\varepsilon_y = 40 \sim 50$ pm, which was still larger than $\varepsilon_y \sim 20$ pm. (18-20 Nov.)

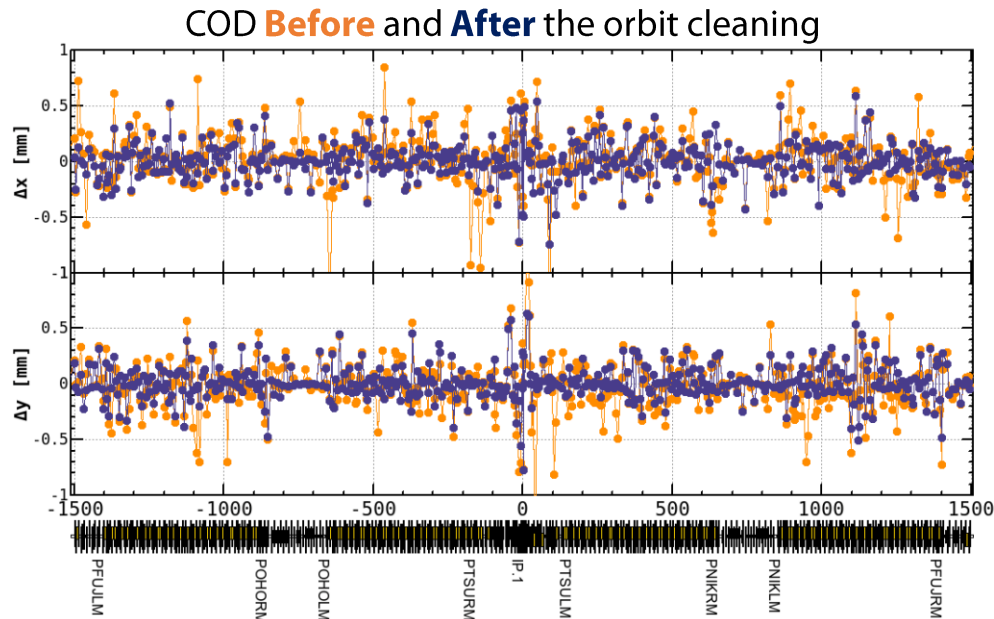

The resonance at $\nu_y \sim 43.605$ is not observed in the simulation with the model lattice. Resonance strength seems to depend on the details of the optics correction.

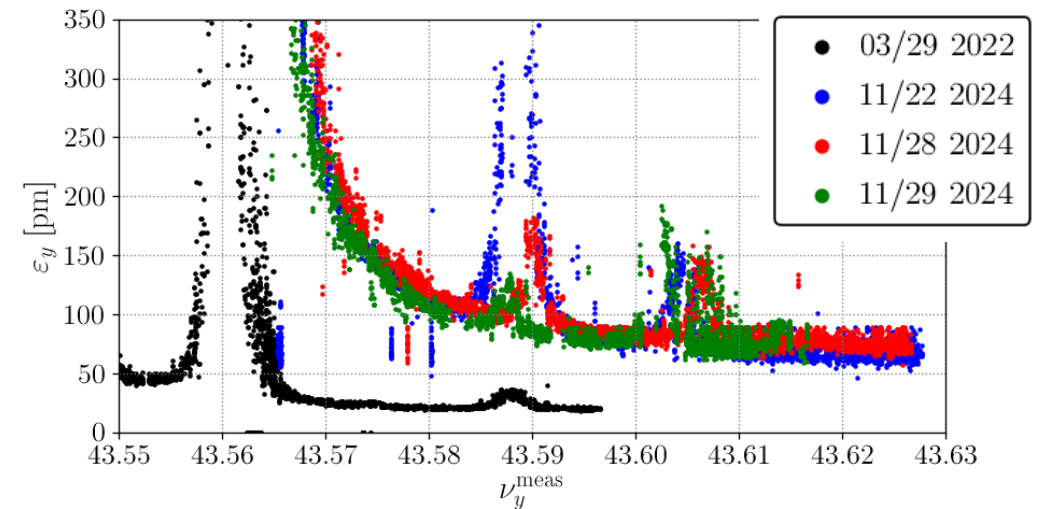

- We tried several attempts to lower the emittance, magnet initialization, IP orbit angle tuning, rollback of magnet settings, and orbit cleaning. But the situation did not improve.
- Something in the HER beamline, unidentified through beam measurements, has changed or broken during the vacuum scrubbing?
- Plan in 2025c: optics correction for the detuned optics from scratch, closest tune approach, any other ideas?

Emittance of single and collision beams

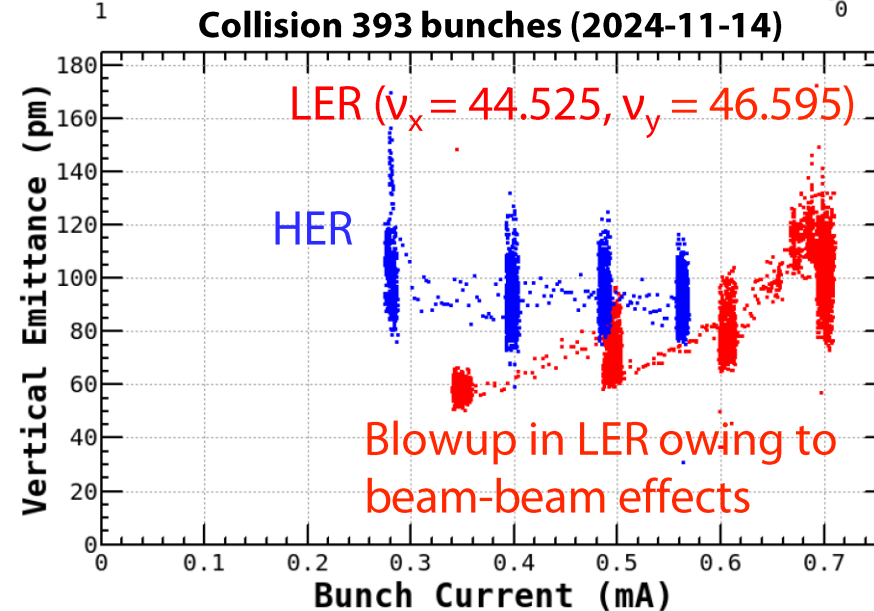
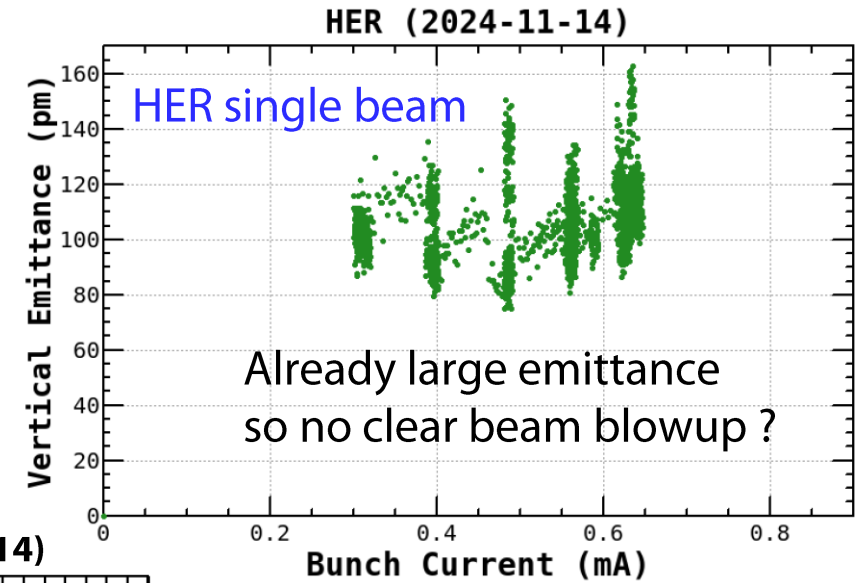
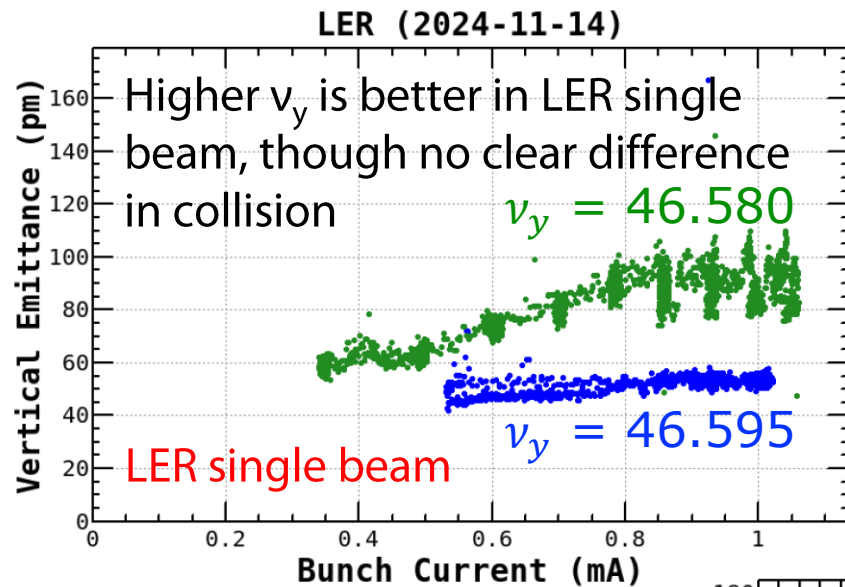

Beam-beam effects

$\beta_x^* = 80$ mm in LER
 ($L_{sp} = 4.5 \times 10^{34}$ cm⁻²s⁻¹, 5 Dec. 2024)

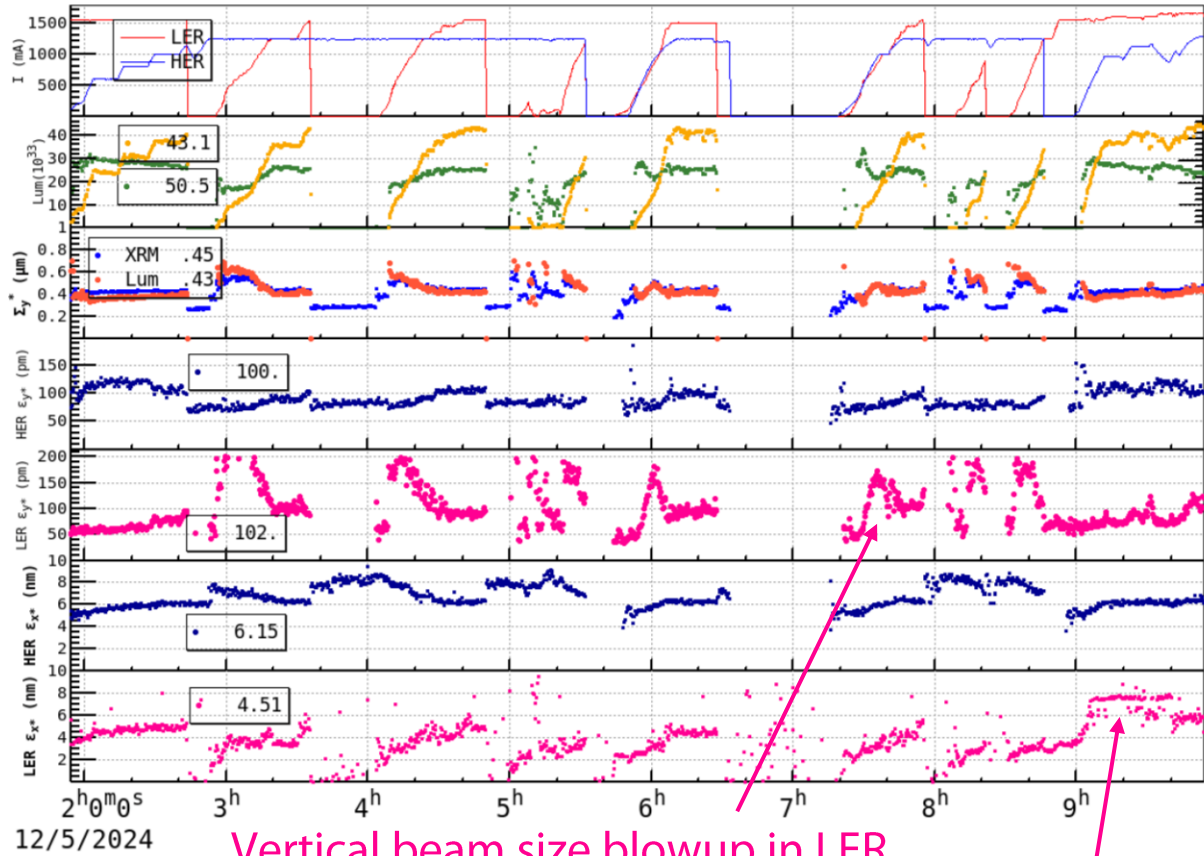

Vertical beam size blowup in LER

Horizontal beam size blowup in LER

$\beta_x^* = 60$ mm in LER
 ($L_{sp} = 5.1 \times 10^{34}$ cm⁻²s⁻¹, 27 Dec. 2024)

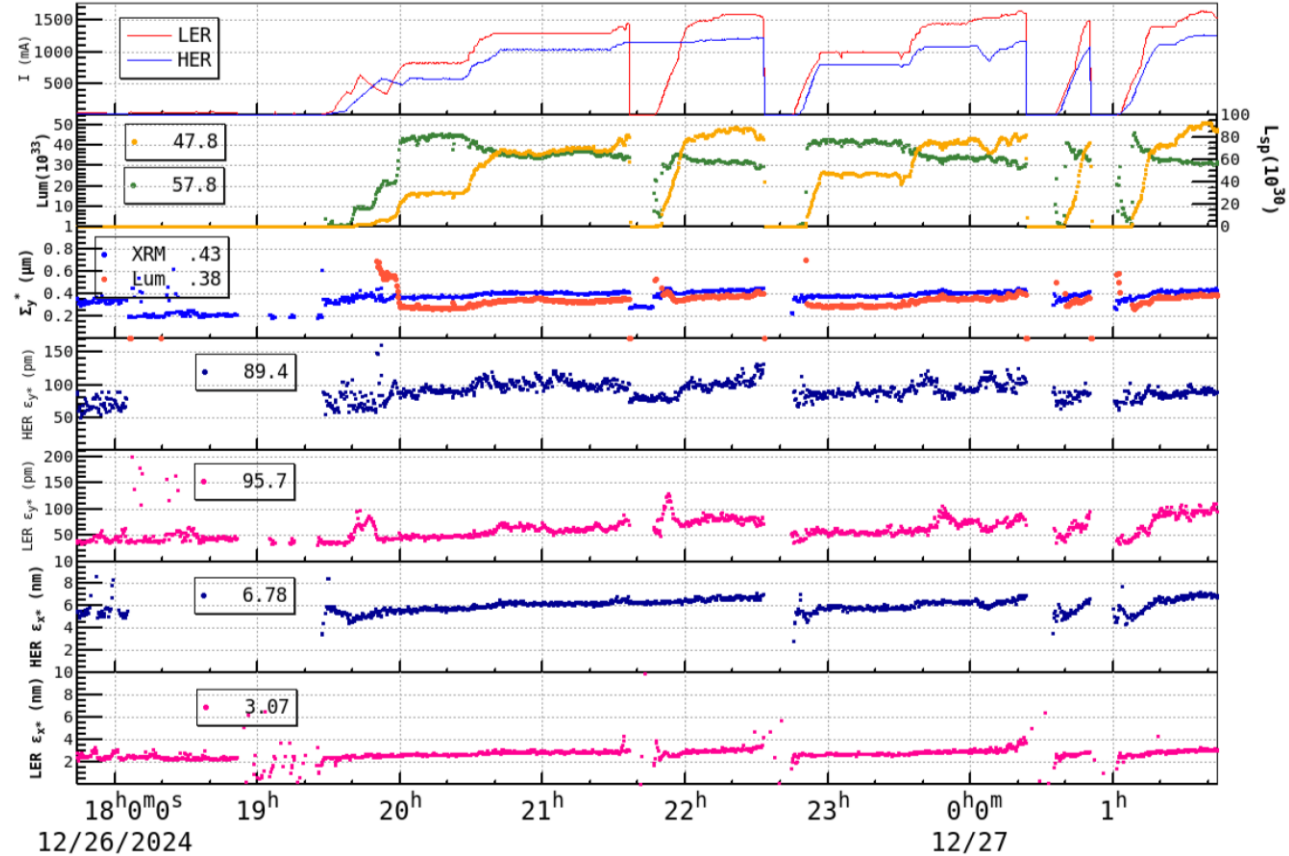

Lowering β_x^* (LER) from 80 mm to 60 mm mitigated synchro-beta or betatron resonances.

Number of pressure-burst events

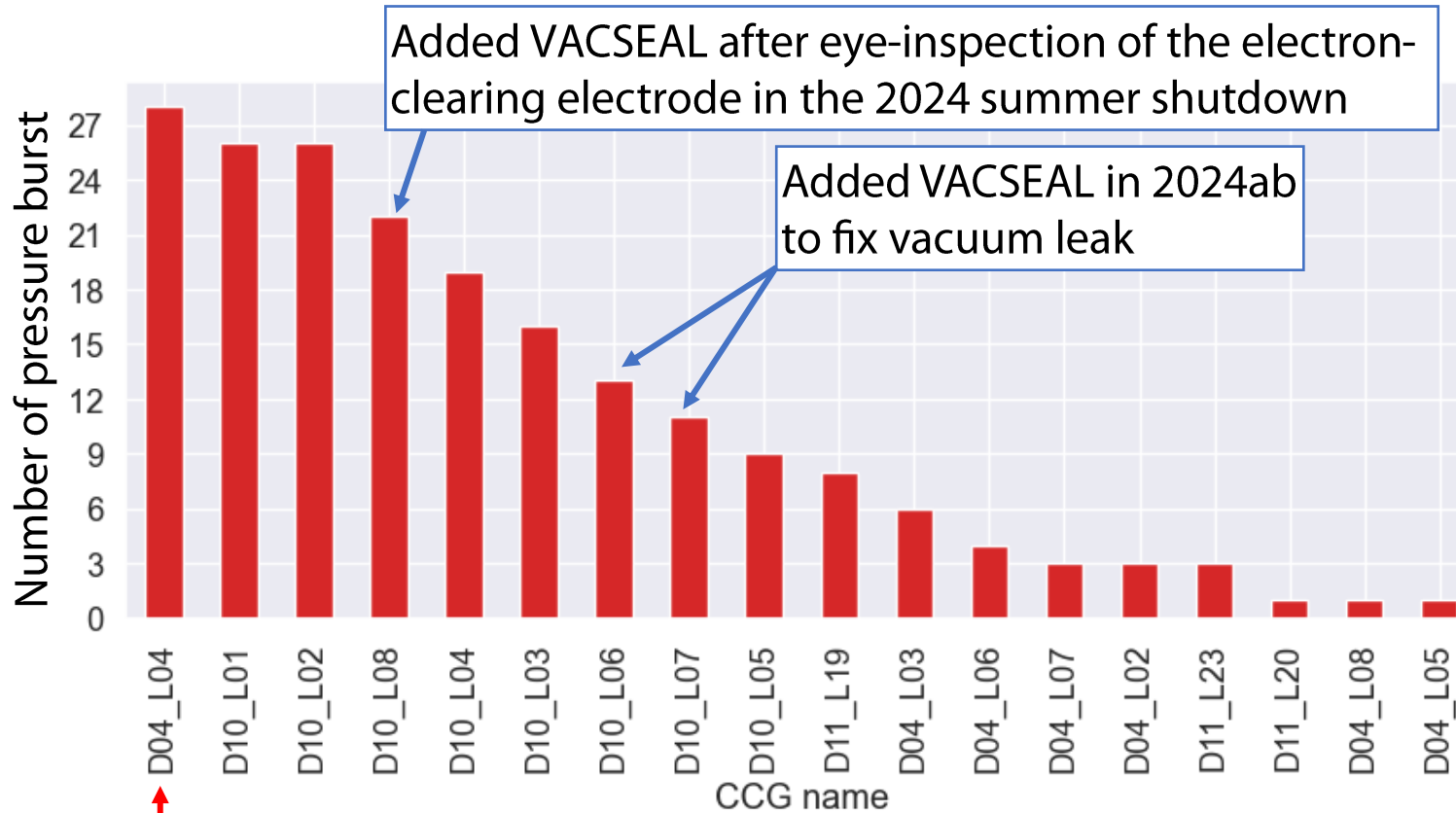

Flipping the beam pipe with the clearing electrode at D04 does not work to remove pressure-burst events.

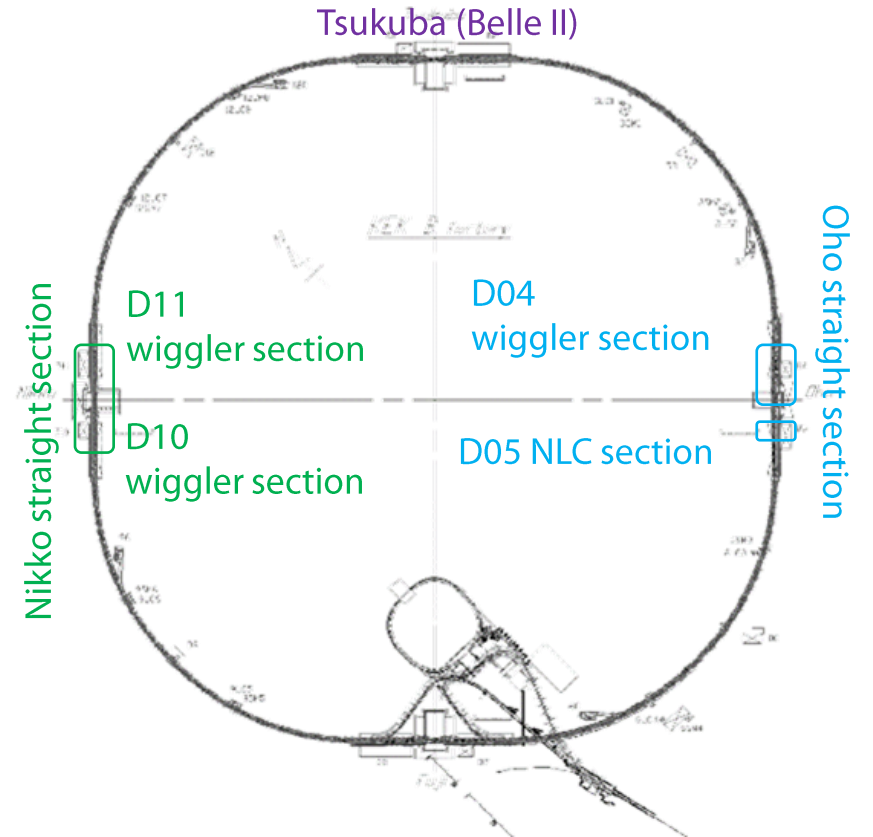

Impact of VACSEAL removal on SBL events

Before removal

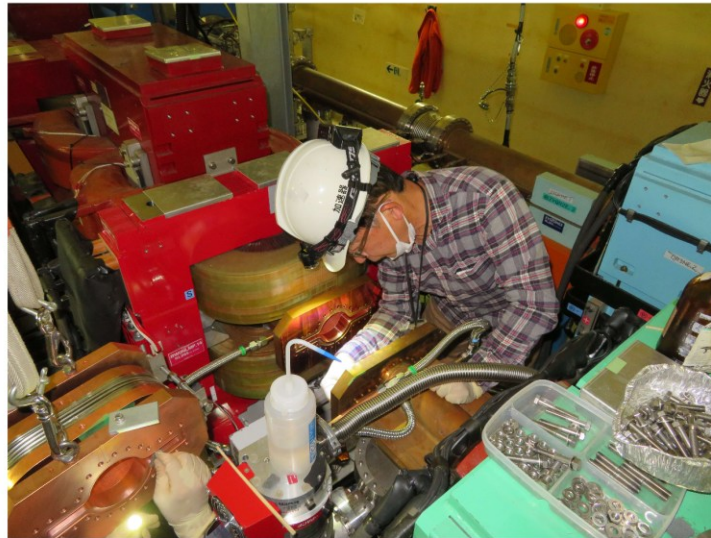
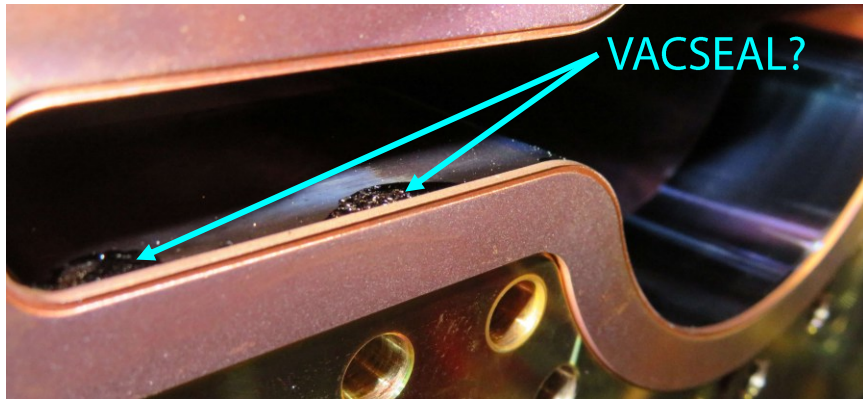

After removal

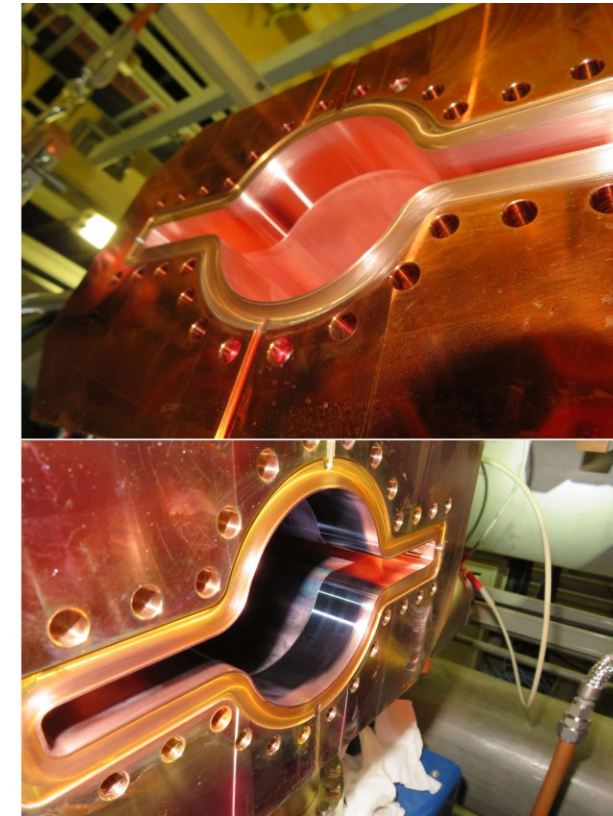

VACSEAL removal reduces SBL events accompanied by pressure bursts.

Oct. 9 - Nov. 6 : #SBL/Beam Dose = 0.141 (1/Ah)

// Bellows chamber at Nikko wiggler section was exchanged on Nov. 6.

Nov. 6 - Dec. 27 : #SBL/Beam Dose = 0.043 (1/Ah) ← including not-removed flanges

Beam abort statistics

2024ab (155 days)

Abort ring	SBL	BeamLoss	Injection	RF	Mag	VA	EQ	Others	Manual	Uncategorized	TOTAL
TOTAL	162	588	1800	134	17	19	37	65	-	2	2824
Both(LER)	128	86	156	2	7	-	-	16	-	-	395
Both(HER)	19	143	1135	2	-	-	-	3	-	-	1302
Both	-	-	-	-	8	-	7	1	-	2	18
LER	15	234	199	75	1	4	5	24	-	-	557
HER	-	125	310	55	1	15	25	21	-	-	552

Many injection-induced aborts in HER

All aborts

2024c (80 days)

ring	SBL	BeamLoss	Injection	RF	Mag	VA	EQ	Tuning	Others	Manual	Uncategorized	TOTAL
TOTAL	114	352	423	63	4	13	9	440	17	-	9	1444
Both(LER)	80	53	31	2	1	-	-	76	6	-	-	249
Both(HER)	18	69	354	-	1	1	-	233	1	-	1	678
Both	-	-	-	-	1	5	2	-	-	-	4	12
LER	15	161	13	32	1	3	1	27	9	-	-	262
HER	1	69	25	29	-	4	6	104	1	-	4	243

Injection-induced aborts significantly reduced

$I_{LER} > 60 \text{ mA}$, $I_{HER} > 60 \text{ mA}$

Abort ring	SBL	BeamLoss	Injection	RF	Mag	VA	EQ	Others	Manual	Uncategorized	TOTAL
TOTAL	139	470	205	84	8	11	30	22	-	1	970
Both(LER)	114	73	63	2	3	-	-	13	-	-	268
Both(HER)	18	131	114	2	-	-	-	1	-	-	266
Both	-	-	-	-	4	-	7	-	-	1	12
LER	7	183	6	49	-	3	3	3	-	-	254
HER	-	83	22	31	1	8	20	5	-	-	170

LER: #SBL/Beam Dose = 0.064 (1/Ah)
 HER: #SBL/Beam Dose = 0.012 (1/Ah)

ring	SBL	BeamLoss	Injection	RF	Mag	VA	EQ	Tuning	Others	Manual	Uncategorized	TOTAL
TOTAL	102	310	76	45	3	7	9	1	15	-	8	576
Both(LER)	72	46	19	2	1	-	-	1	5	-	-	146
Both(HER)	18	64	52	-	1	1	-	-	1	-	1	138
Both	-	-	-	-	1	1	2	-	-	-	3	7
LER	12	146	1	20	-	2	1	-	8	-	-	190
HER	-	54	4	23	-	3	6	-	1	-	4	95

LER: #SBL/Beam Dose = 0.074 (1/Ah)
 HER: #SBL/Beam Dose = 0.020 (1/Ah)

Injection related beam abort

(Courtesy of K. Uno, Belle II)

2024c:

- Relaxed the diamond threshold only during injection ($\Delta_{inj} = 400$ us)
- Enlarged injection veto of Belle II CLAWS from Oct. 25: 400 us \rightarrow 600 us
 - Several CLAWS only aborts (inj. related) occurred, but the frequency was reduced
236 times (Oct.9 – Oct.25), 55 times (Oct.26 – Dec.27)

Eg. Number of injection related aborts after **the maintenance days**

- The frequency is significantly reduced!
- \rightarrow **We could smoothly restart the operation**

		# aborts	#aborts/day
2024b	Apr. 17, 18, May. 15, 16 Jun. 12, 13	185	30.8
2024c	Oct. 30, 31 Nov. 27, 28	7	1.8

119/185: VXD only
aborts

Frequency of SBLs in LER

(Courtesy of K. Uno, Belle II)

- Several SBLs with pressure burst at D10 occurred in beginning of 2024c
- The bellows chamber b.t.w D10_L02 and D10_L03 was replaced on Nov. 6th
 - No SBLs with pressure burst at D10 L02/D10 L03 after the replacement
- Removed VACSEAL in some chambers at D10 on Nov. 27th
 - The frequency of LER SBL at D10 was further reduced.
- The frequency of SBL at D04 was high in Dec
 - The average IR dose is huge in case of SBL at D04. → Many QCS quenches

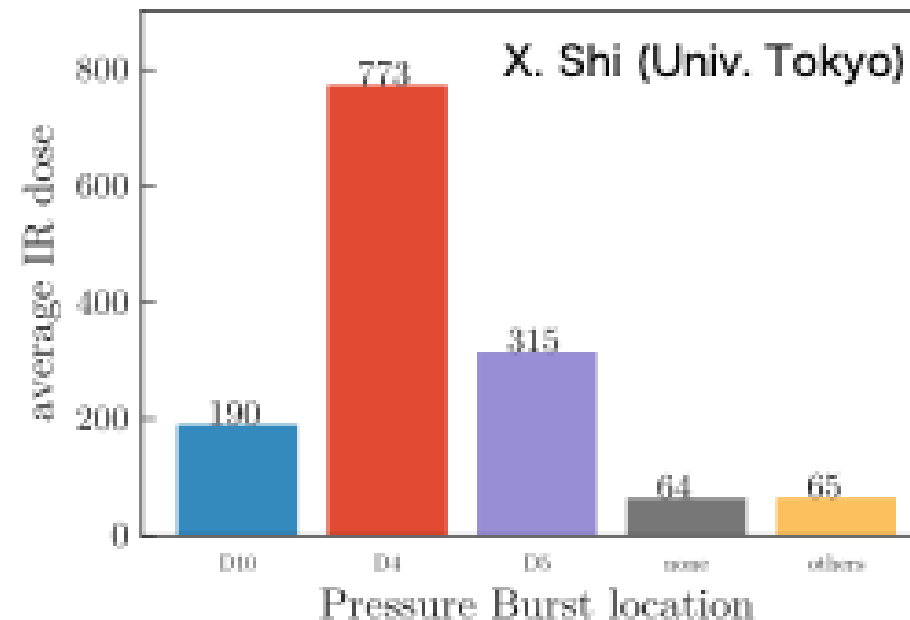
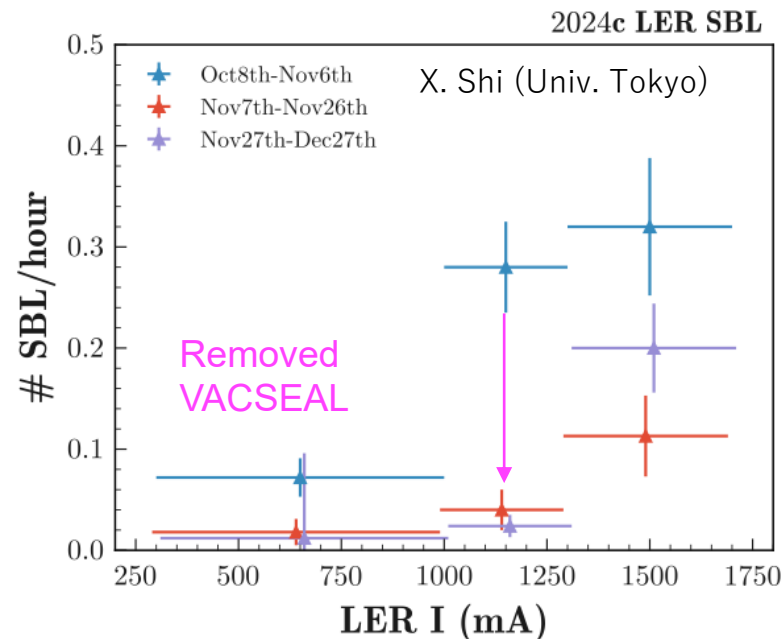

Outline

- Summary of 2024c operation
- Highlights from Linac operation
- Highlights from MR operation
 - Beam injection & Nonlinear collimator
 - Emittance blowup
 - Beam-beam effects
 - Sudden beam loss events
- **Preparation for 2025c operation**
- Plan & Summary

Scheduled work in 2025 shutdown

- **Linac RF gun replacement**
 - The new RF-gun cathode will be delivered by the end of March and installed next summer.
- **ECS installation at BTe**
 - The accelerating structure will be installed at BTe by the end of March, and new ECS will be available from the 2025c run.
- **Bending magnet replacement at BTp**
 - A few old bending magnets will be replaced next summer.
- **Countermeasure against SBL**
 - Inner cleaning & VACSEAL removal in the pipes and bellows
 - Flipping the beam pipes with electrodes at the Nikko wiggler section canceled
 - CCG added near IP in HER
- **Radiation shielding reinforcement and expanding radiation control area near Oho Experimental Hall.**
 - Required for achieving higher LER beam current using NLC at OHO.
- **Various work to be done by the Plant and Facilities Department**
 - Roof renovation in Tsukuba, 6 kV HV power cable replacement

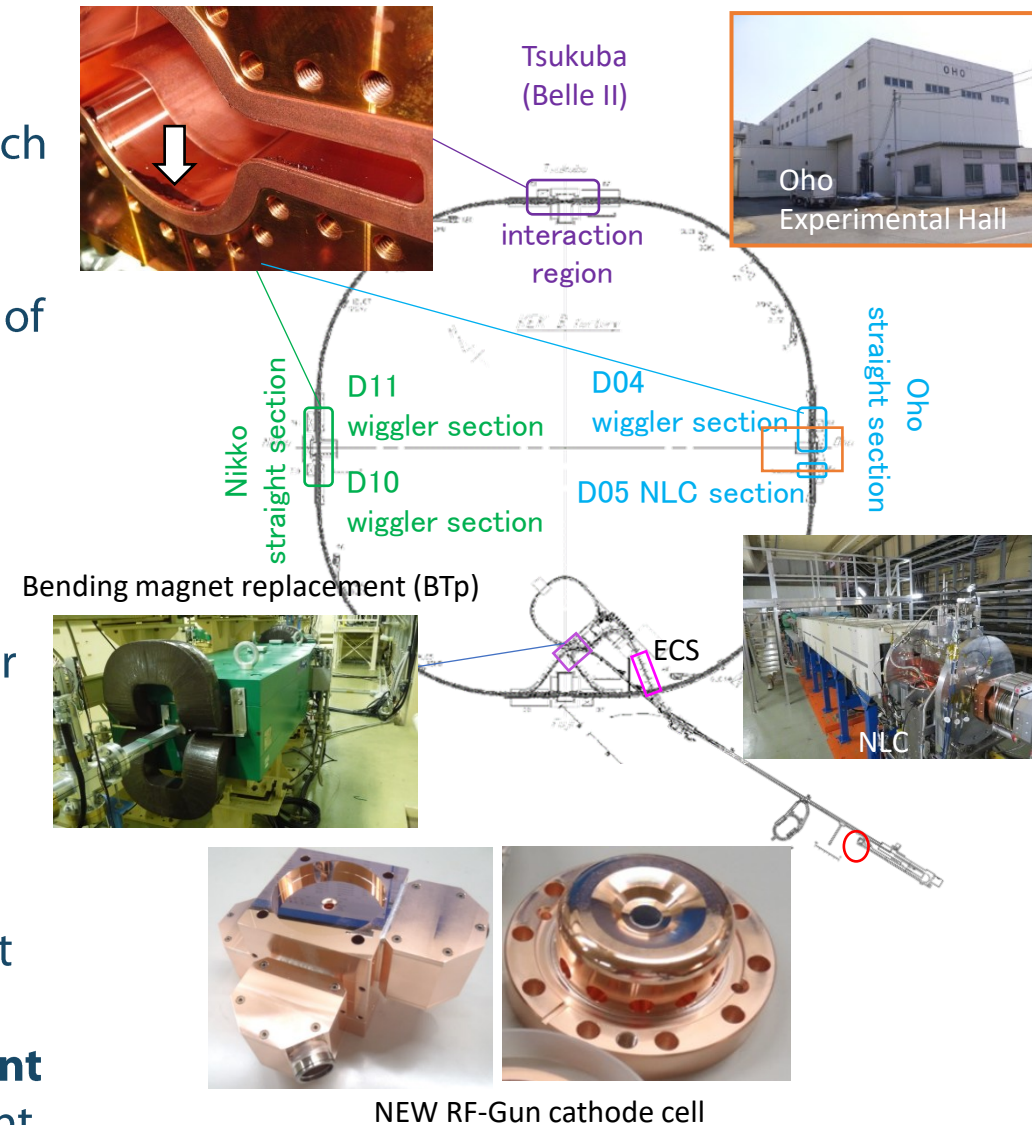

Further removal of VACSEAL

- **VACSEAL removal is planned at**
 - IR: All "MO flanges" that appear to have used VACSEAL (no removal is planned for the flanges using the Helicoflex seal).
 - LER D04: All flanges at the wiggler section
 - LER D10: All flanges at the wiggler section
 - LER D11: Flanges showing pressure burst in the wiggler section
- Additionally, VACSEAL has been used on the bellows of some LER collimators.
 - The collimators D02V1 and D05V1 will have their heads replaced, and VACSEAL will be checked then.
- **Removal has been partially completed in IR and LER D04.**
 - In IR, some black stains were found on both rings, which we believe are VACSEAL.
 - In D04, though not significant, there were also some black stains.
- We didn't use VACSEAL during the beam pipe flipping work at D04 in the 2024 summer shutdown.
- For chambers with TiN coating, we do not remove the black stains because removal work may cause the TiN coating to fall off.

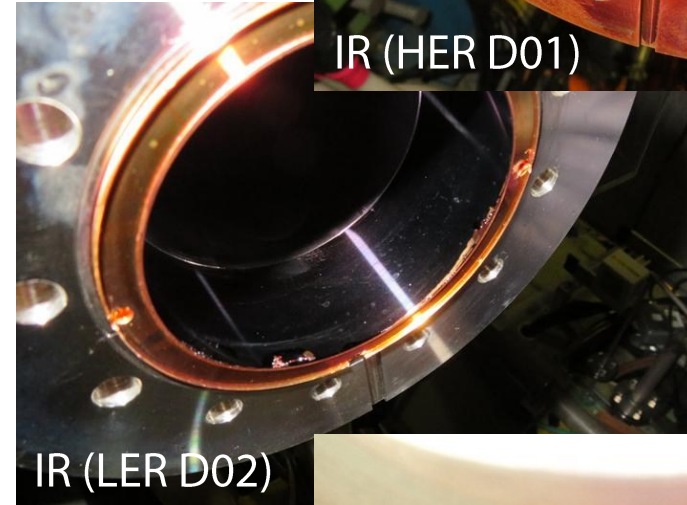

Radiation shielding reinforcement at Oho

We investigate and plan the reinforcement with Prof. Y. Sakaki (KEK Radiation Science Center):

1. Extend the lead+polyethylene shield around the beam pipe by 5 m
2. Add a shield next to the “gantry shield”
3. Add a gantry polyethylene shield around the D05V1 collimator
4. Extend the radiation-controlled area with a fence around the Oho experimental hall

(Courtesy of Y. Sakaki, Radiation Science Center)

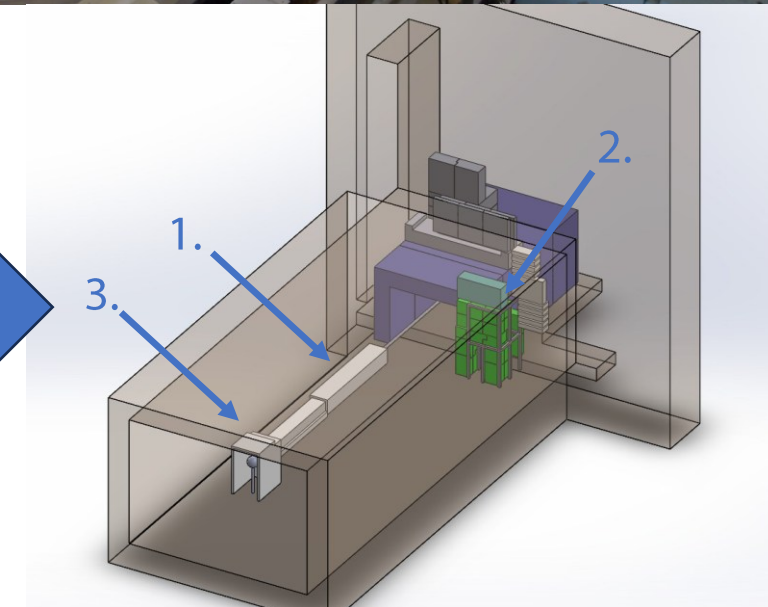
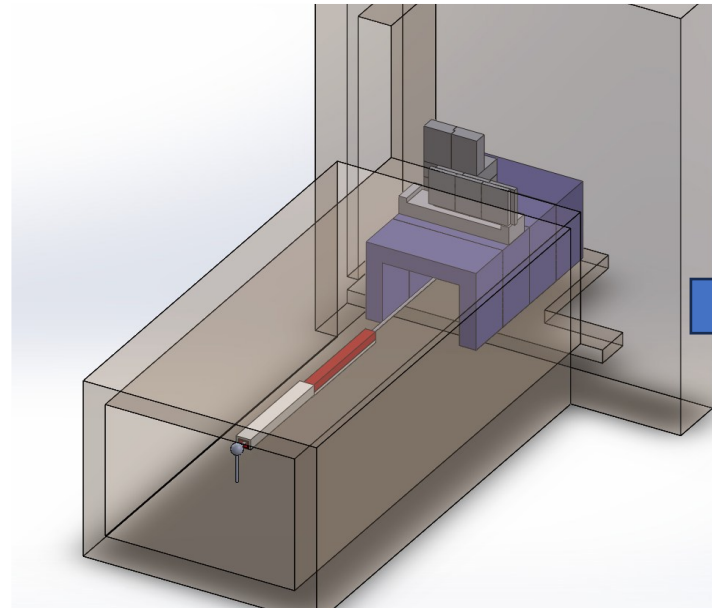
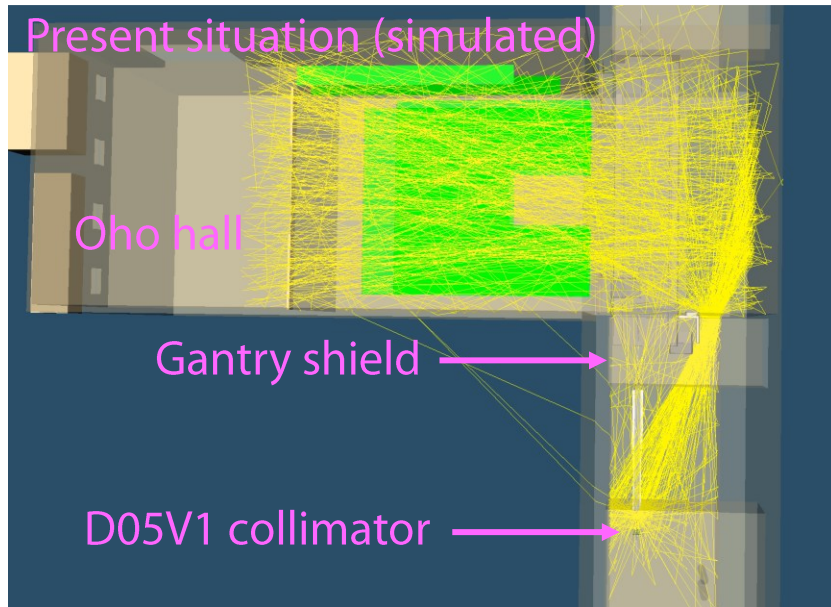

Work under consideration in 2025 shutdown

- **LER D06V2 collimator relocation to D03 Arc section**

- To protect Belle II and D02V1 collimator from uncontrollable beams
- The best location is currently being determined.

- **Countermeasure against HER SBL**

- We need to do something, but we don't have concrete plans yet.

- **And so on...**

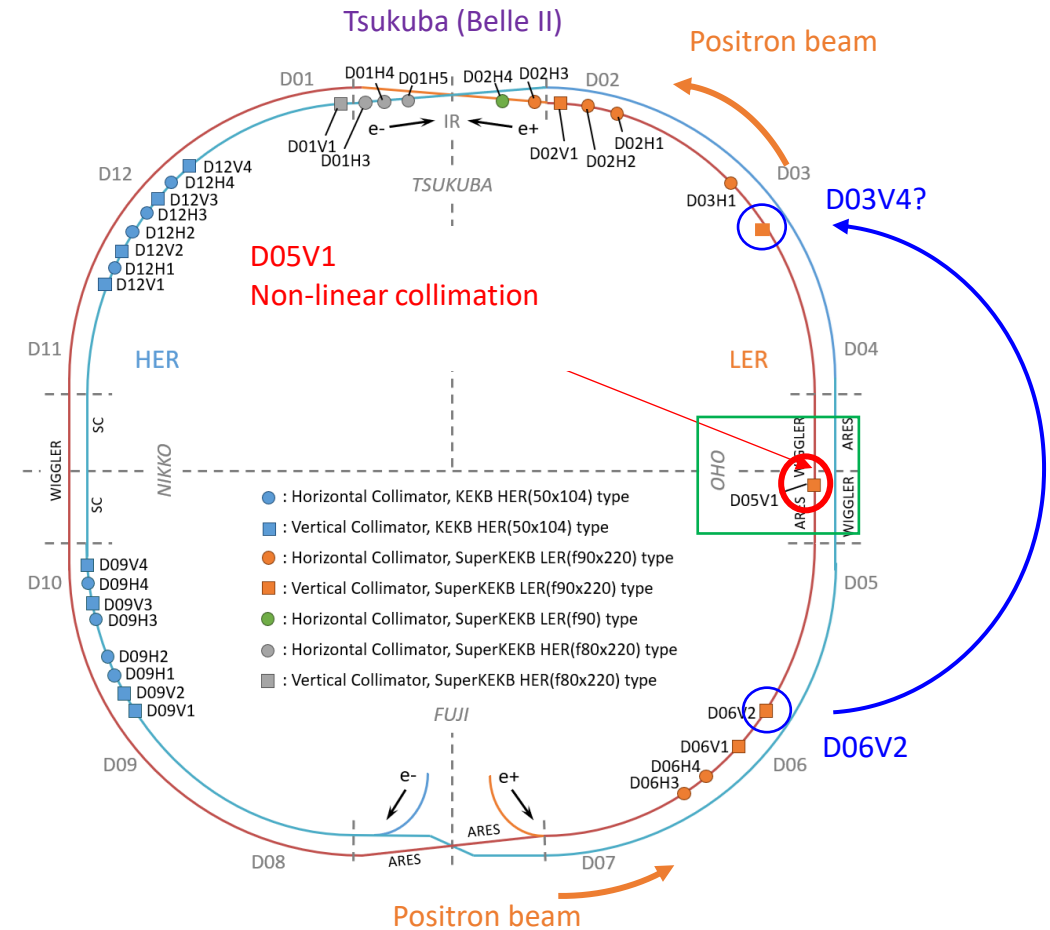

Outline

- Summary of 2024c operation
- Highlights from Linac operation
- Highlights from MR operation
 - Beam injection & Nonlinear collimator
 - Emittance blowup
 - Beam-beam effects
 - Sudden beam loss events
- Preparation for 2025c operation
- **Plan & Summary**

Plan in 2025c operation

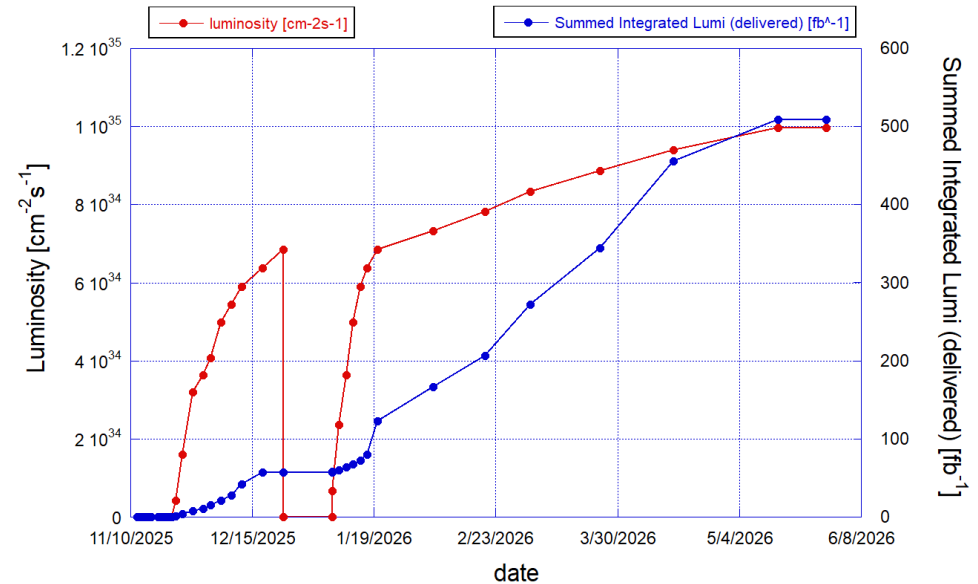
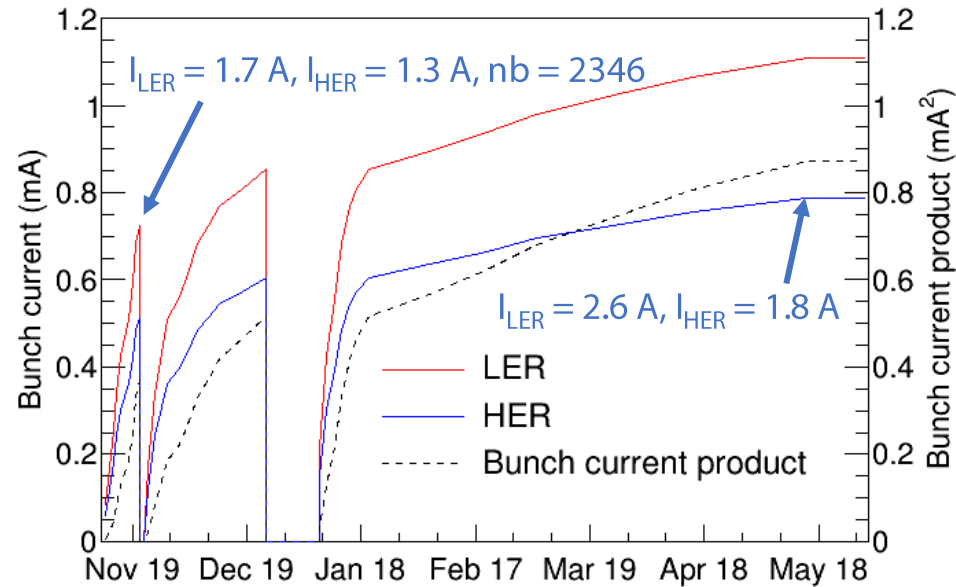

- **Target luminosity for the 2025c-2026b operation until the end of May 2026**

- Peak luminosity: $1 \times 10^{35} \text{ cm}^{-2} \text{ s}^{-1}$
- Integrated luminosity: 425 fb^{-1} (plus the present stat. 575 fb^{-1} gives 1 ab^{-1})

- **Operation schedule**

- November 2025 through the end of May 2026, with a 2-week winter shutdown
- Schedule of the off-resonance run is under discussion.
- At this time, we may not have enough electricity for 5 months. For the Feb.-Mar. and Apr. 2026 operations, we will later determine whether to continue or suspend the operation based on the operation status and electricity bill.

Plan in 2025c operation

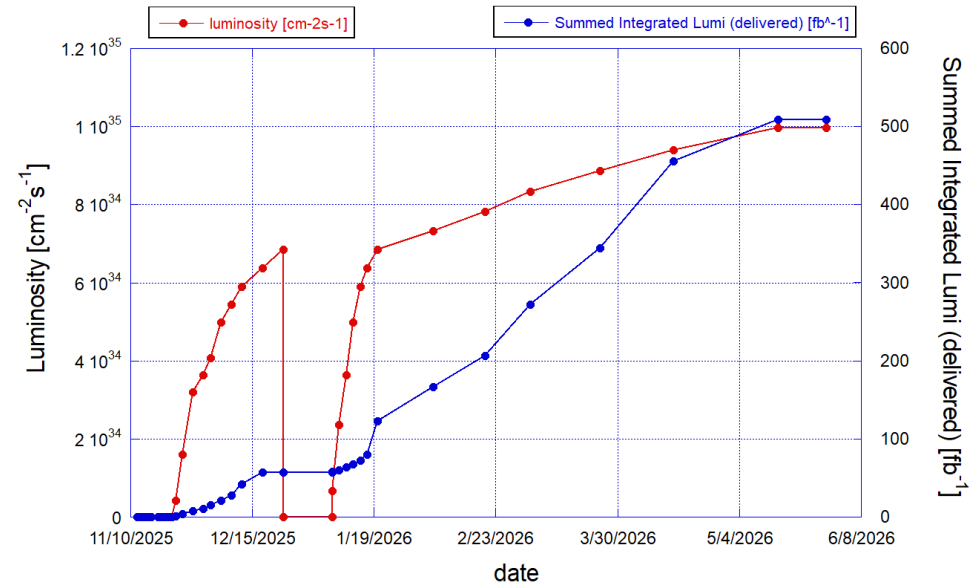
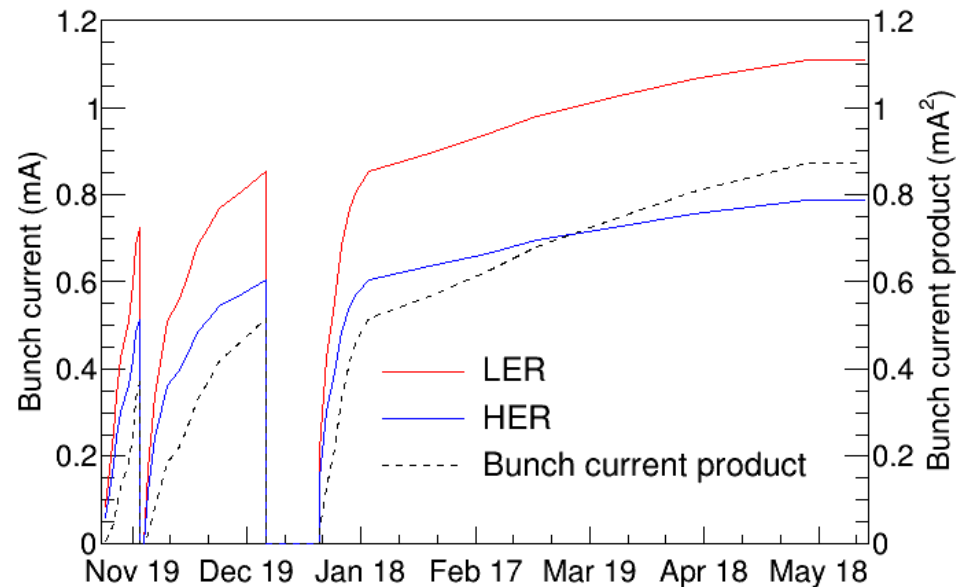

• Operating parameters

- Machine parameter details, such as β_y^* and number of bunches, and physical run/study ratio are under consideration.
- We plan to squeeze β_y^* and will take machine time to make β_y^* adjustments.
- Squeezing β_x^* will be done depending on the operating conditions.
- Usage of NLC is under discussion and needs machine study time in 2025-2026:
 - keeping $\beta_x = 3$ m for reducing injection background as in 2024c (impact on injection efficiency)
 - or other β_x , etc.

Summary

- **Peak Luminosity**

- $5.1 \times 10^{34} \text{ cm}^{-2}\text{s}^{-1}$ at $\beta_x^* = 60 \text{ mm}$, $\beta_y^* = 1 \text{ mm}$, $I_{\text{LER}} = 1.63 \text{ A}$, $I_{\text{HER}} = 1.26 \text{ A}$, $n_b = 2346$ (note: Belle II HV off)

- **Achievements, findings, and issues**

- 2-bunch operation almost always in LER, although it was prevented in HER due to RF-gun discharging
 - RF gun cavity will be replaced in this summer.
- Squeezing β_x^* mitigates beam-beam-induced horizontal beam blowup in LER.
 - Squeezing $\beta_{x,y}^*$ in 2025-2026 needs more simulation and discussion to determine the strategy.
- Vacuum leak sealant “VACSEAL” was found to be a strong candidate for causing SBL events.
 - Removal work at IR, D04, and D10 has started and partially completed.
- Large vertical emittance has remained in 2024c compared with 2022ab and 2024ab
 - Plan in 2025-2026: optics correction for the detuned optics from scratch, closest tune approach, etc.
- Beam-beam effects
 - Investigation and intensive simulation study are in progress together with experts from US, EU, and China.

Backup

2023/2-2024/12のKL_A1_Bのパルス幅、Es(電力を決めるパラメータ) とバンチ電荷



パルス幅 1.0 ms, Es 31.2 で2ndバンチの実績なし。
この条件で出せるかどうか不明かつHER入射に十分な質までもっていけるかも不明。
エキスパートの経験ではたぶん無理という判断。

Before

HER

After

Red : Beam Current in HER

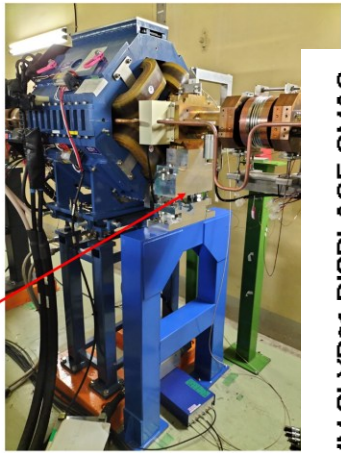
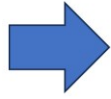
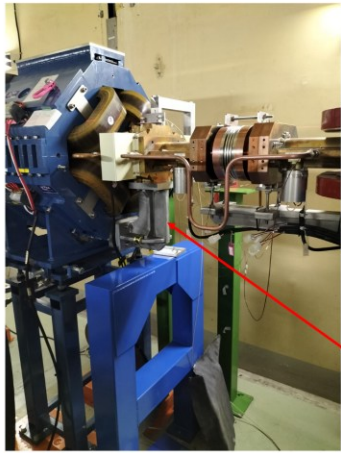

Movement of Quad

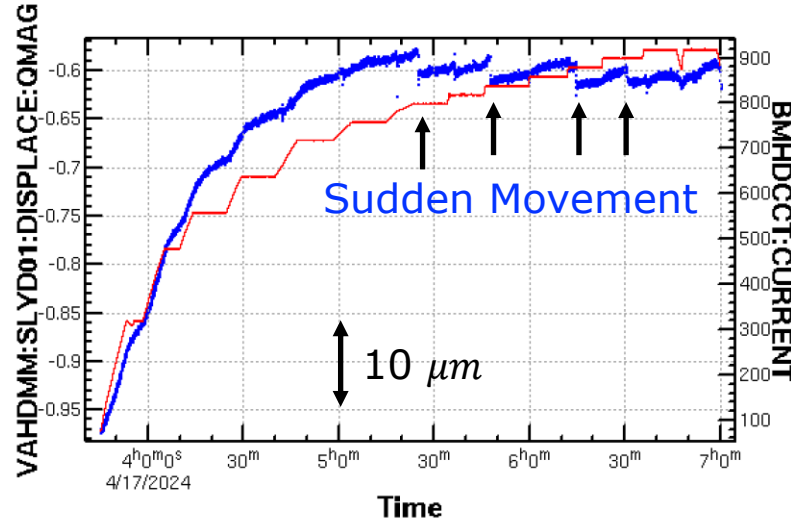

Movement of BPM Block

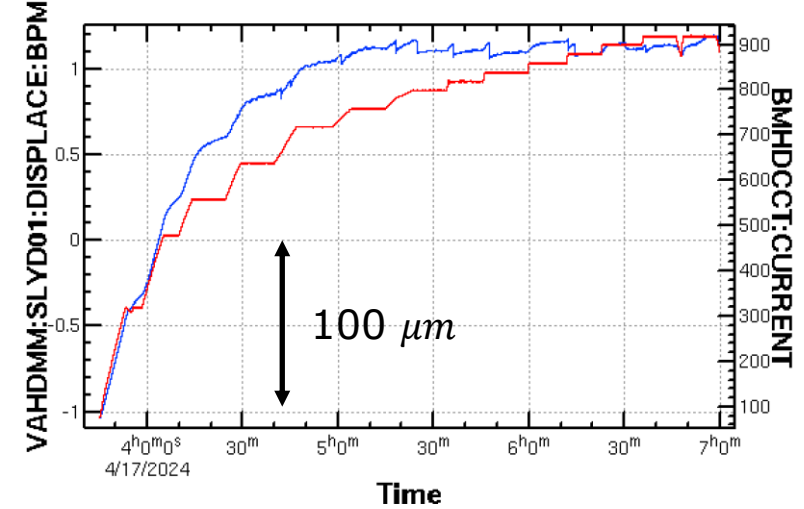

Remove BPM support from Quad

Work on April 17 2024

After Modification

1 V = 100 μm

We don't observe Sudden Orbit Distortion after Isolation Work.

No unidentified beam abort occurs.

Horizontal orbit shift at sextupoles induces large beta-beat and tune shift.

No Movement of Quad

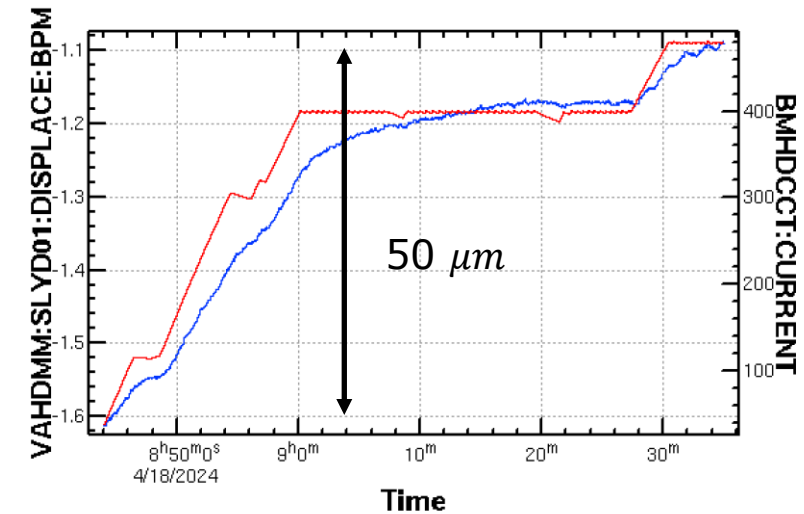
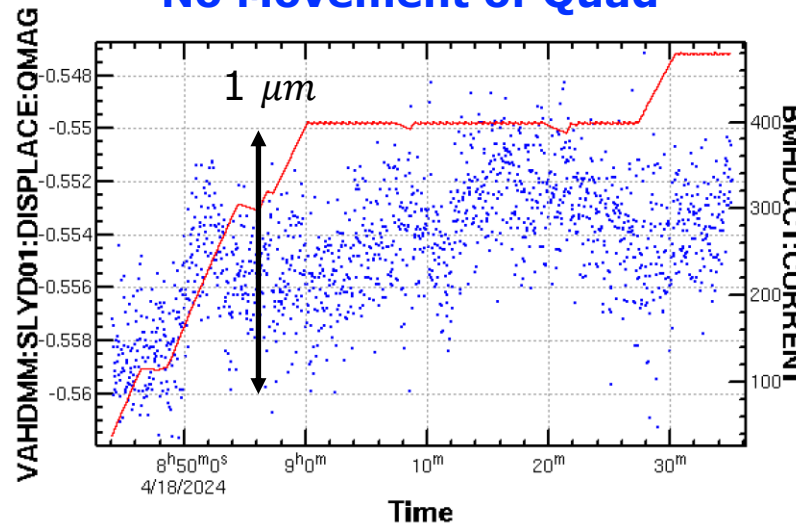

Beam-beam effects

Bunches at the head of train are short lifetime in LER.

LER

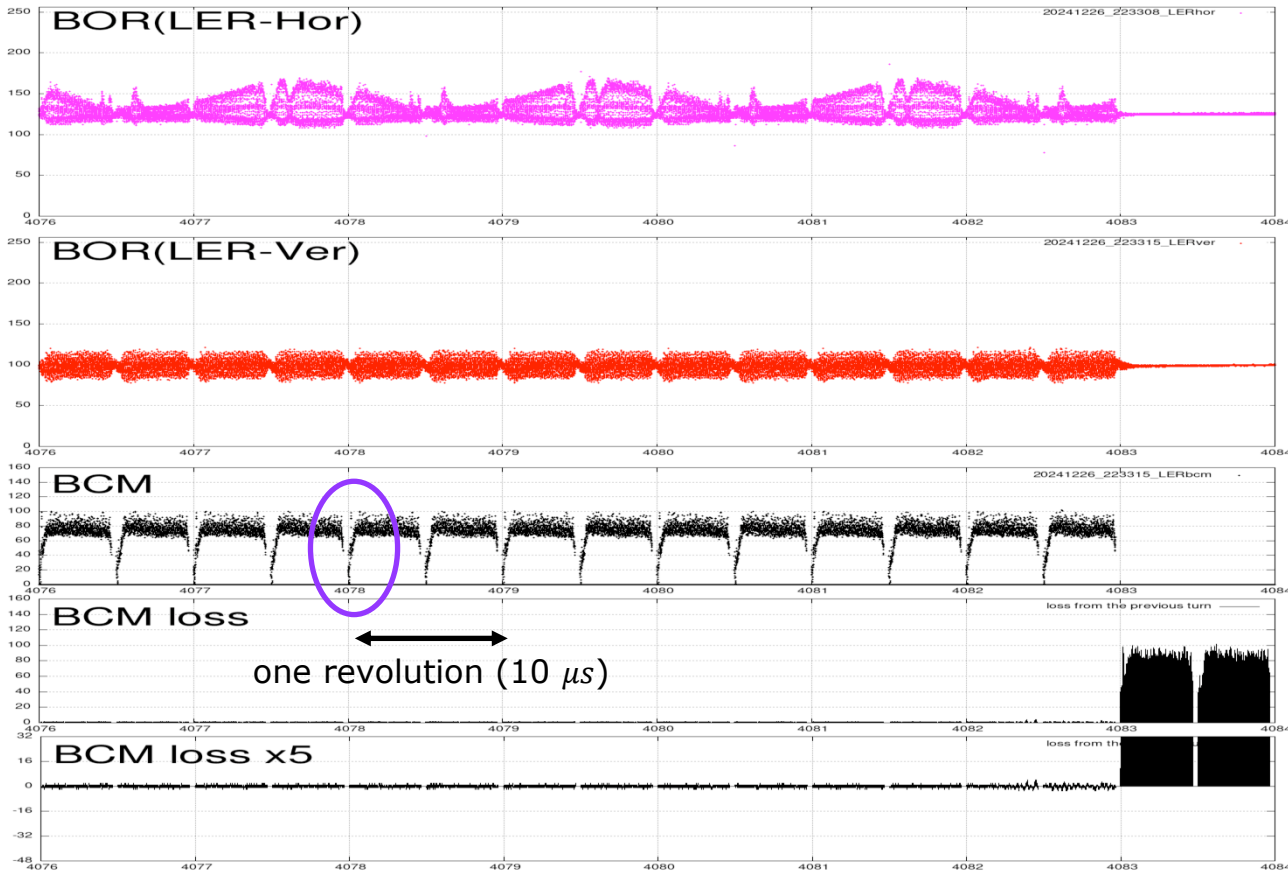

Model horizontal tune is very close to half integer to keep nominal tune.

