

PULSED MAGNET CONTROL SYSTEM USING COTS PXIE DEVICES AND LABVIEW

Y. Enomoto*, K. Furukawa, T. Natsui, M. Satoh, KEK, Tsukuba, Japan
H. Saotome¹, Kanto Information Service, Tsukuba, Japan

Abstract

About one hundred channel of pulsed magnet power supply control system was installed in 2017 in KEK electron positron LINAC to realize pulse-to-pulse control of output current every 20 ms. The control system totally consist of commercially available devices, namely a computer (Windows 8.1), a PXIe crate and several PXIe boards such as ADC, DAC communication and timing. The software is written by LabVIEW. EPICS channel access protocol is used to communicate with OPI over standard Ethernet network. Depending on the destination of the beam, there are ten beam mode. The software is able to keep parameters for each mode independently, which makes it possible for us to operate one LINAC as if it were ten virtual LINACs. During two years of operation, there were no significant problem. Although the Windows is not a real-time OS, dropping rate of the trigger coming every 20 ms is less than ppm. Rebooting the computer or software is only a few times in a year.

INTRODUCTION

The KEK injector linac [1] has delivered electrons and positrons for particle physics and photon science experiments for more than 30 years. Figure 1 shows electron and positron accelerator complex in the KEK Tsukuba site. There are four storage rings, i.e. two rings for light source, PF and PF-AR, and two rings for electron positron collider, SuperKEKB [2] HER and LER. In addition to them, positron damping ring have been in operation since February 2018. All of the rings require full energy injection, 2.5 GeV for PF, 6.5 GeV for PF-AR, 4 GeV for SuperKEKB LER and 7 GeV for SuperKEKB HER as shown in the Fig. 1.

In 2009, simultaneous injection to three rings but PF-AR were realized [3] with common DC magnet settings. However, in the SuperKEKB era from 2016, the previous scheme has no longer valid due to strict requirement for injection beam to the SuperKEKB rings. Table 1 compares several required injection parameter for the KEKB rings and SuperKEKB rings. One of the big difference is that the beam life time in the SuperKEKB rings expected to be as short as 6 minutes that was 150 or 200 minutes in the KEKB rings. Usually, it takes at least a few minutes to load the parameters for PF-AR ring, injection into the ring and reload the parameters for SuperKEKB rings. It is not acceptable for the SuperKEKB rings to stop injection for such a long time, otherwise most of the particles in the SuperKEKB rings have been lost. Another difference is the emittance requirement to the SuperKEKB rings. To avoid emittance growth in the

LINAC, optics and orbit setting should be optimized for both of the rings which require different injection energy.

To satisfy these requirements, about one hundred pulsed magnets were installed in 2017 and 2018 Using these magnets, magnetic field can be changed shot by shot in 20 ms and was optimized for each destination.

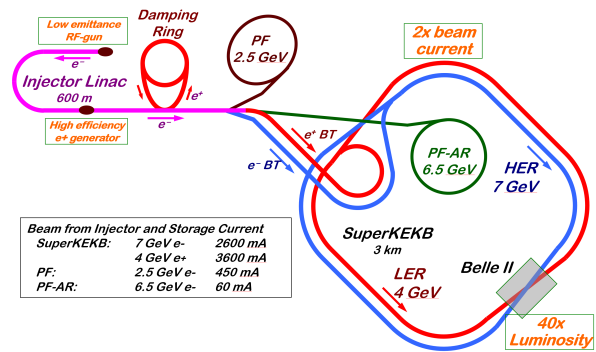

Figure 1: A schematic view of the electron and positron accelerator complex in the KEK.

Table 1: Required Injection Parameters

Stage	KEKB		SuperKEKB	
	electron	positron	electron	positron
Beam Energy (GeV)	8.0	3.5	7.0	4.0
Life time (min.)	200	150	6	6
Emittance (μm)	310	1400	40/20 (H/V)	100/15 (H/V)
Bunch charge (nC)	1	1	4	4
Energy spread (%)	0.13	0.13	0.07	0.16

In this paper, the control system and software are mainly described. Details of the hardware such as magnet, power supply circuit are found in the reference [6].

OVERVIEW OF THE SYSTEM

Concept and overview

There are many requirements for the power supply to truly realize the required flexible operation. In addition, since the required number of the power supply is not a few, unit cost,

* yoshinori.enomoto@kek.jp

installation space, energy efficiency are crucially important. Trigger rate of our LINAC is 50 Hz, but injection pattern is not fixed. The destination of the beam is delivered by the EVENT timing system via optical fiber just after the previous pulse. To interpret the information and change setting within 20 ms, fast and intelligent control system is necessary. To realize these requirements with minimum risks and cost, we decide to develop new power supplies by ourselves following the concepts bellow .

- realize high efficiency with energy recovery
- separate power circuit and control system
- use commercially available components as much as possible
- compatible with existent EVENT timing system
- compatible with existent EPICS control system [4]

Figure 2 shows a block diagram of the pulsed power supply system [5]. One standard unit which covers 4 quadrupole and 4 steering magnets, shown in Fig. 3, consist of a PXI express unit for fast control, DC power supplies, pulse drivers and NI cRIO unit for interlock and slow data acquisition.

In addition, there is one computer to control and monitor all of the DC power supplies (DC power supply control server). A CSS archiver and A Network attached storage are used to log various data not only output current of the power supplies but temperature of the IGBT in the pulse driver, status of the DC power supplies and others. EPICS channel access protocol is mainly used for the communication among computers over the standard network. LXI ver 1.3 protocol is used to control the DC power supplies and NI network shared variable is used to send fast waveform data. As for the event timing system, dedicated optical fiber is directly connected to the module. Most of the software is written by LabVIEW 2016 (32 bit) with NI DSC module and running on Windows 8.1.

pulse driver

Pulse driver in fig.2 is one of the core components of the pulsed power supply. For the steering magnets, the pulse driver mainly consists of a power operational amplifier. The driver linearly amplifies control signal from the DAC. For the quadrupole magnets, the pules driver consists of IGBTs and capacitors. Unlike usual switching power supplies, output current is controlled by the voltage between gate and emitter. From the view point of the control system, both pules drivers for steering and quadrupole magnets work as power amplifier and output current is controlled by the voltage of the DAC. In addition, the pulse drivers have output current monitor which is independent from the one used for the feedback control of the circuit in the driver. The output voltage of the monitor is proportional to the output current To monitor the signal is important for the debugging the system in the case of trouble.

Thus the requirement for the controlling system of the pulsed driver is simply equivalent to how to control the DAC and ADC synchronised with beam.

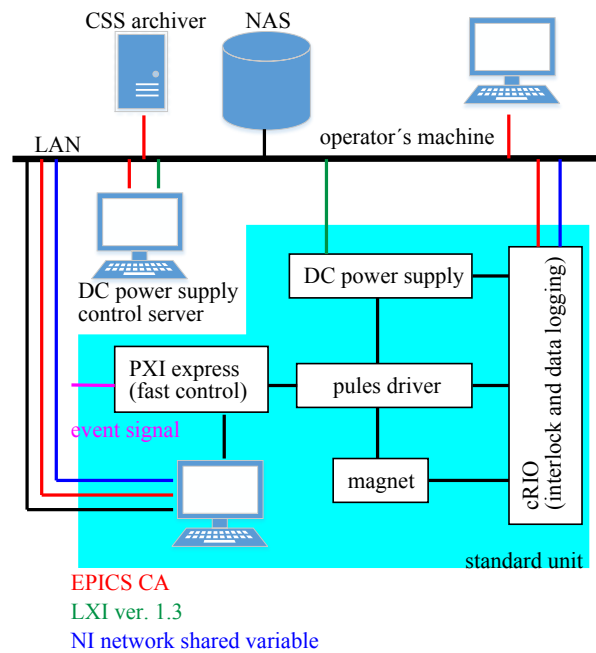

Figure 2: Block diagram of the power supply control and monitor system.



Figure 3: A photo of the standard unit for 4 quadrupole and 4 steering magnets.

SELECTION OF THE CONTROL BUS AND DEVICES

As is often the case with many facilities, VME bus is widely used for the communication bus of the many devices especially ones which require timing control. Event timing system of MRF is used in our LINAC for the timing control. Thus the Event receiver with VME bus is common in our environment. However, this time, PXI / PXI express bus was

chosen for the pulsed magnet power supply control system. The reasons are

- availability of the EVR module
- availability and cost of ADC and DAC boards
- promising standards
- fast bus speed

Not only the timing and trigger control but also many information such as destination of the next beam, shot ID and others are delivered by the Event Timing System. It is necessary for the new system to be compatible with the present Event Timing System. Fortunately, EVR module with PXI bus was available.

Although many ADC and DAC boards are commercially available, sometimes it is not so easy to obtain the one suitable for the purpose. Developing the board from the IC will usually time-consuming and not cost effective for a small scale system.

Looking back the progress of the PXI / PXI express bus standards last 20 years, it is revised as new PCI / PCI express standards appear in the market. As long as the PCI / PCI express is adopted for the computer bus, PXI / PXI express is expected to be maintained.

As for the performance, bus speed of the crate used in the system (NI PXIe-1082) is up to 8 GB/s which is much faster than that of the latest VME standard. It is suitable for the transfer of the large amount of data from the ADC and DAC.

Figure 4 shows the details of the PXI control system. One unit consists of the

- a remote controller card (NI PXIe-8381)
- an 8 ch 16 bit 1MHz simultaneous sampling ADC (NI PXIe-6356)
- an 8 ch 16 bit 1MHz simultaneous updating DAC (NI PXI-6733)
- an EVR (MRF PXI-EVR-230)
- a chassis (NI PXIe-1082)
- a computer with Windows 8.1 and LabVIEW

Embedded controller with PXI express bus was not adopted intentionally. The controller is a general PC. The life cycle of the CPU is generally shorter than that of ADC and DAC boards. Separation of the CPU makes it possible for us to upgrade the system more flexibly with less cost in the future.

SOFTWARE

In our LINAC, EPICS is used for the infrastructure of the device control. The new system must be compatible with EPICS. In addition, since control boards made by National instruments were adopted, it is straightforward to choose LabVIEW for the programming language. Fortunately there are software modules in LabVIEW to connect EPICS.

Figure 5 shows data flow in the software. Twelve DAC data array according to the beam mode (ten beam mode plus no injection mode and no trigger mode) are prepared in advance in the computer's memory. Each DAC data is recalculated by putting a new value using EPICS channel access

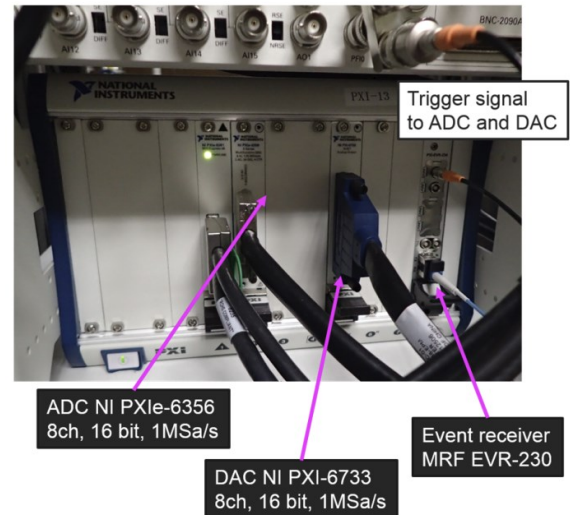
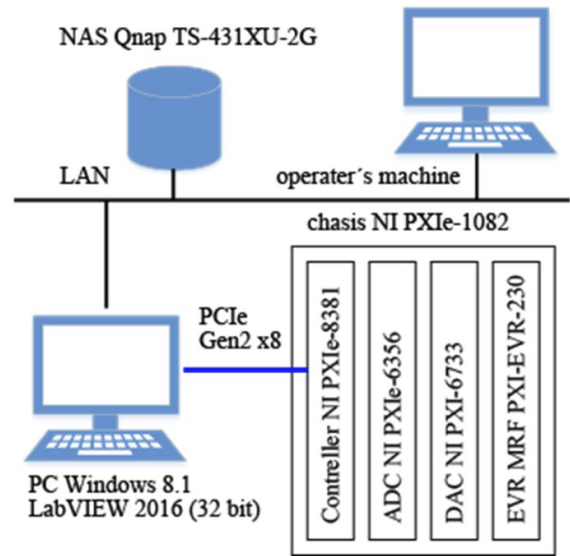

Figure 4: Details of the PXI unit (top) and its outlook (bottom).

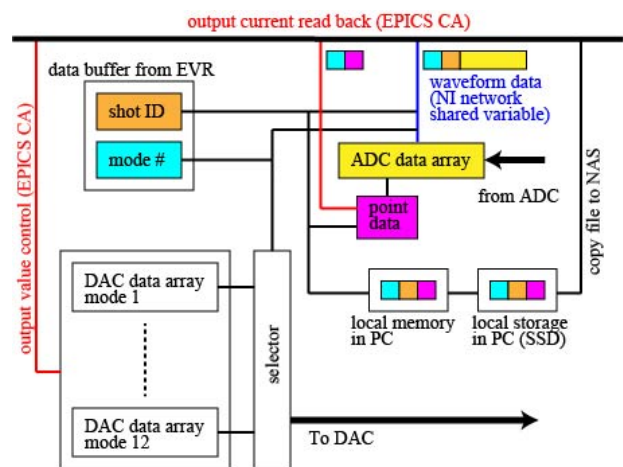

Figure 5: Data flow in software

protocol. Data buffer information from the EVR is delivered to the main software a few milliseconds after the last trigger.

Then, one of the DAC data array is selected according to the next beam mode and updated to the DAC's memory. By the trigger signal from the EVR, the DAC and the ADC start outputting and digitizing data for 6 ms. Acquired ADC data array is concatenated with shot ID and mode number, then issued to the network using NI network shared variable protocol every 20 ms. At the same time, one point, at the timing of the beam passing through, in the ADC data array is chosen and issued to the network with mode number using EPICS channel access protocol. Every one point data with timestamp, shot ID and mode number is buffered in the memory of the control computer for 10 s then they are dumped to the text file in the local storage of the computer. The file is copied to the NAS every 60 s by another process. By this way, output current of the power supply for all of the shot (every 20 ms) is stored in the disk. The amount of the data is about 3 TB/year. In addition to real-time monitoring, logging by CSS archiver every 10 s is also available for all the channel. Supplemental softwares such as, remote monitoring ADC data array, detecting hung-up of the main programs etc. are also prepared by LabVIEW and runnig on the windows machine in the control room.

EVALUATION AND OPERATION

trigger dropping rate

The combination of Windows 8.1 and LabVIEW make it possible for us to develop software in short time. However, as is well known, Windows is not a real-time operating system. Whether the software is able to do all the tasks in 20 ms or not depend on the performance of the computer. The specifications of the computer used in operation are summarized in table 2.

Table 2: Required Injection Parameters

	manufacturer	type
CPU	Intel	core-i7 6700
motherboard	ASRock	Z170 Extreme6+
memory	crucial	CT4K4G4DFS8213
storage	crucial	CT525MX300SSD1
power supply	corsair	RM550x

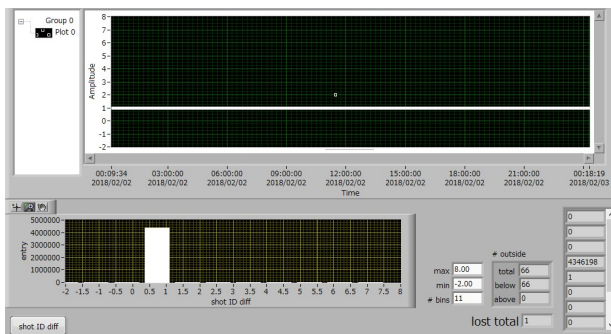

Figure 6: Difference of the adjacent shot ID for one day at one unit.

Figure 6 shows trigger dropping rate for one day at one unit. Shot ID is stored in the log file for every output pulses. If the trigger was not dropped, difference between adjacent shot IDs should be one. The upper graph shows this value as a function of time and the lower one shows the histogram of them. In this example one trigger is dropped among 4.32 million pulses. (50 Hz repetition means 4.32 million pulses per day.) Data from other unit and other day shows similar results, namely trigger dropping rate is less than 1 ppm. Even though this is a kind of Brute-force solution and the dropping rate depend on the conditions, the value is acceptable for our present operation.

experiences during two years operation

Long term stability of the Windows and LabVIEW is also one of the concern. Presently, 16 units are in operation. Most of the unit except for a few specific unit are very stable. It is not necessary to restart the software and reboot the PC during the operation term more than 6 months. Unstable units require reboot once in a few months. Although the reasons is not clear, difference of the noise environment is one of the candidate.

SUMMARY

Since the major installation of the pulsed magnet system in the summer shut-down 2017, there has been no severe trouble during two years operation. Although the system using Windows and LabVIEW is not a real-time system, trigger dropping rate is less than one ppm, which is practically sufficient for the present operation. The control system in this paper which fully utilize the COTS devices might be a possible candidate for the medium-scaled control system.

REFERENCES

- [1] M. Akemoto *et al.*, "The KEKB Injector Linac", Prog. Theor. Exp. Phys. **2013** (2013) 03A002, doi:10.1093/ptep/ptt011
- [2] Y. Ohnishi *et al.*, "Accelerator design at SuperKEKB", Prog. Theor. Exp. Phys., **2013**, 2013, 03A011, doi:10.1093/ptep/pts083
- [3] M. Satoh, "FIRST SIMULTANEOUS TOP-UP OPERATION OF THREE DIFFERENT RINGS IN KEK INJECTOR LINAC", in Proceedings of LINAC2010, Tsukuba, Japan, pp.703-707 (2010)
- [4] A. Akiyama *et al.*, "Accelerator Control System at KEKB and the Linac", Prog. Theor. Exp. Phys., **2013**, 2013, 03A008, doi:10.1093/ptep/pts081
- [5] Y. Enomoto *et al.*, "A NEW PULSED MAGNET CONTROL SYSTEM IN THE KEK ELECTRON POSITRON LINAC", in Proceedings of IPAC2018, Vancouver, BC, Canada, pp.2121-2123 (2018)
- [6] Y. Enomoto *et al.*, "PULSE-TO-PULSE BEAM MODULATION FOR 4 STORAGE RINGS WITH 64 PULSED MAGNETS", in Proceedings of LINAC2018, Beijing, China, pp.609-614 (2018)