

DESIGN AND FABRICATION SIMULATION OF C⁶⁺ HSC LINAC FOR CANCER THERAPY WITH DPIS

Ling Lu, Toshiyuki Hattori, Noriyosu Hayashizaki

Research Laboratory for Nuclear Research, Tokyo Institute of Technology, Tokyo, Japan

Abstract

A new type Linac, HSC (hybrid single cavity) linac for cancer therapy, which configuration combines RFQ (Radio Frequency Quadrupole) accelerating structure and DT (Drift Tube) accelerating structure is being finished designs and simulations now. This HSC linac design has adopted advanced power-efficiency-conformation, IH (Interdigital H) cavity which acceleration efficiency is extremely high in the low-middle energy region [1], and has also adopted advanced computer simulation technology to evaluate cavity electromagnetic distribution. The study purpose of this HSC linac is focus to design of injector linac for synchrotron of cancer therapy facilities.

INTRODUCTION

The study purpose of HSC linac research is design of a new type injector linac for synchrotron of cancer radiotherapy facilities with DPIS (Direct Plasma Injection Scheme) by laser ion source [2]. The largest feature of HSC linac is that its structure combined RFQ accelerating structure and DT accelerating structure into one IH cavity could accelerate C⁶⁺ ions up to 2-3MeV/u from 25keV/u in 2-3 meters. But this structure would also make cavity electric field distribution difficult to evaluate. For application compared with conventional acceleration system, the system applied HSC linac has an excellent space effect and simplified effect of operation because of compact size by coupled complex acceleration electrode and integrated the peripheral device. The image of HSC linac is shown as Fig.1.

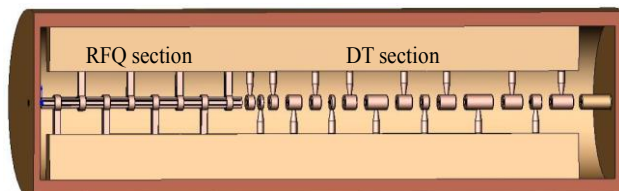

Fig.1: Inner image of HSC linac.

The largest feature of HSC is a hybrid structure which is combined RFQ structure and DT structure into one IH cavity.

In this work we finished the designs and simulations of 10mA HSC model which could accelerate C⁶⁺ ions up to 2.0 MeV/u from 25 keV/u in 2 meters with lower 100kW feeding power. The operation frequency of HSC linac is 100MHz. For the RFQ section which could accelerate C⁶⁺ ion up to 220keV/u from 25keV/u, its length and diameter are 681.8 mm and 255mm, for the DT section which include 17 cells and could accelerate C⁶⁺ ion up to final energy from 220keV/u, its length and diameter are 1128.2 mm and 650 mm.

The soft PERMTEQ and PMLOC were adopted to calculate orbit computation (RFQ and DT), and the soft Microwave Studio was adopted to evaluate cavity

electromagnetic field distribution.

The linac cavity design in this work had implemented an advanced power-efficiency-configuration, APF-IH structure, which has high acceleration efficiency in the low-to-middle energy region.

And for linac fabrication, a integral-cut method which has no need of alignment is adopted a 5-axis (NC) numerical control machine to fabricate the integral main frame (including acceleration structure which includes drift tubes, stems and ridges).

HSC LINAC DESIGN AND SIMULATION

RFQ Design and DT Design

In this HSC linac design, 4 rod IH type RFQ structure, which was design to accelerate C⁶⁺ ions up to 220keV/u from 25keV/u, was adopted. This structure is suitable to accelerate heavy ions and suitable to use for HSC linac IH cavity. The exit phase spectrum and energy spectrum designs of 20mA RFQ calculated by PARMTEQM are convergent design. The beam profile at RFQ exit is shown as Fig.2.

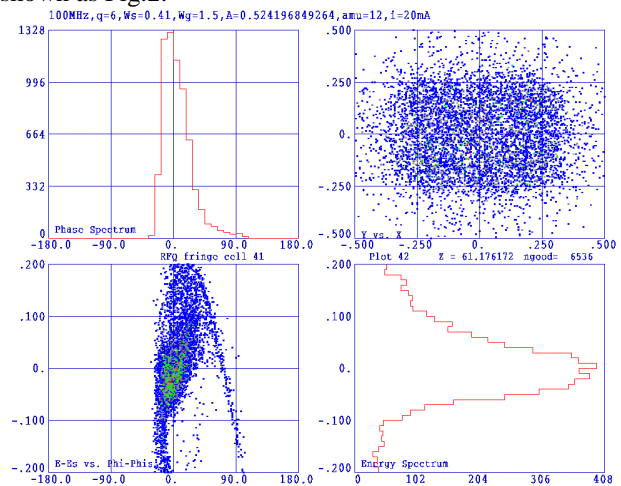

Fig.2: The beam profile at exit of RFQ.

The designs of phase spectrum and energy spectrum are adopted convergent design for following DT injection.

#lu.l.ad@m.titech.ac.jp

This 20mA RFQ design includes 31 accelerating cells in total length of 681.8mm. The transmission of beam is 65.4%. The main parameters are listed in table.1.

Charge to mass ratio (q/A)	6/12 (C ⁶⁺)
Operation frequency (MHz)	100
Input energy (keV/u)	25
Output energy (keV/u)	220
Cell numbers	31
Rod radius (mm)	6.1 (0.75r ₀)
Transmission	65.4%
Synchronous phase	-90° → -30°
Maximum field (Kipat.[3])	1.8

Table.1: Main parameters of RFQ design for HSC linac.

For DT design, which was design to accelerate C⁶⁺ ions up to 2MeV/u from 220keV/u, was based on PMLOC (Pi-Mode Linac Orbit Calculation) which was developed by thin lens theory and matrix method. The beam was focused by APF (Alternative Phase Focus) method.

Fitting for design target of 2-3 meters HSC linac, the DT design of HSC is adopted 16 accelerating cells in 1128.2mm. The DT design parameters are listed in table.2.

Charge to mass ratio (q/A)	6/12 (C ⁶⁺)
Operation frequency (MHz)	100
Input energy (keV/u)	220
Output energy (MeV/u)	2
Cell numbers	16
Bore radius (mm)	8
DT radius	24
Synchronous phase	30°, 30°, -30°, -30°

Table.2: Main parameters of DT design for HSC linac.

Design for Electric Field Matching Section

In this work, the electric field distribution was investigated by Microwave studio simulation of HSC model which was only configured by RFQ structure and DT structure (the structure same to Fig.1). The results of model simulation showed that the electric field is focused in the connection parts of 4-rod and first DT. Shown as Fig.3, beam in gap of rod and 1st DT will be subjected to strong accelerating force, and it should be considered that discharge could be led to high voltage and beam acceleration could be received negative influence by unbalance electric distribution.

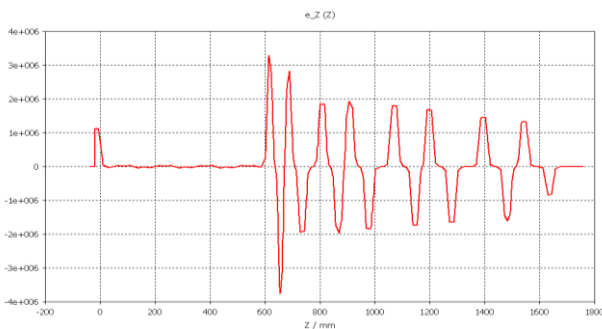

Fig.3: Axial electric field distribution simulated by Microwave studio. Concentrated electric field distribution

in joint part of rods and DT is possible to be occurred discharge and unbalance electric distribution in following DT section.

For reducing this concentrated electric field distribution, Q magnet triplet (QMT) structure, end rod additional radial match (ARM) structure and drift tube finger (DTF) structure had been concerned and discussed. These structures are shown as following Fig.4.

Based on Microwave Studio simulations, shown as Fig.5 the QMT structures and DTF structure could markedly reduce the concentrated electric field distribution. The ARM structure is on simulation now.

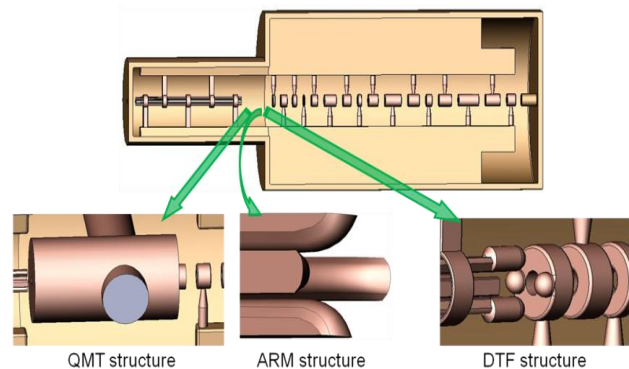

Fig.4: The image of three structures: QMT structure, ARM structure and DTF structure

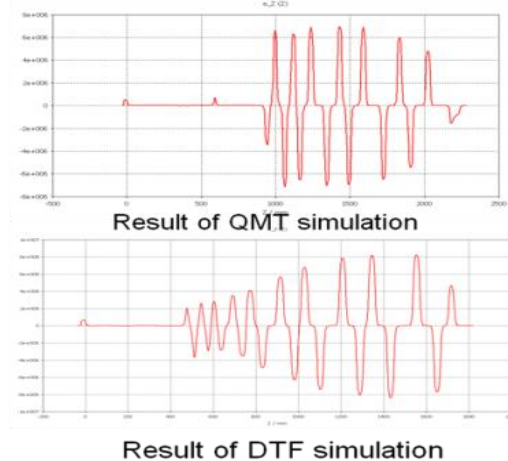

Fig.5: The simulation results of the QMT and DTF structure.

But very hardness for QMT structure fabrication, QMT structure was abandoned firstly. And the details of ARM structure were discussed with Mr. Jameson in Mar 19th at our lab. Mr. Jameson said that the existing PARMTEQ soft could not design and calculate the ARM structure

The design of DTF structure based on Microwave Studio simulation and PMLOC orbit calculation is adopted one gap with 4 fingers figured two vertical rods and horizontal direction of 1st DT. The details of design with phase are shown as Fig.6. The orbit calculation results showed that the transmission of DTF is 85% and the energy is also accelerated 1% (22keV/u).

Power Simulation

For cavity simulation, the relations of mesh and power & frequency were investigated firstly shown as Fig.6. According to simulation, (1) the frequency has an increasing trend with mesh growth. In this HSC cavity case, the frequency of 35 million mesh is 1 MHz bigger than 1.7 million meshes; (2) opposite to stable DT power (necessary power for accelerating C^{6+} ions up to 2MeV/u from 220keV/u), half power is reduced for RFQ side acceleration from five million mesh; (3) the simulated Q value has not big vibration. It could be considered that 1.7 million meshes is enough to calculate frequency and 5 million meshes is necessary for power calculation. And the reason could be considered that the capacitance in RFQ is focusing and lower meshes (less than 5 million) is not enough for calculation of electric distribution.

The frequency is proportion to capacitance (have a equation of $f \propto 1/\sqrt{LC}$) and the power is square proportion to voltage which is a proportion of capacitance ($P \propto V^2, V \propto 1/C$). In case of insufficient capacitance calculated by lower mesh, the inaccuracy of power is bigger than frequency.

Based on these results, electromagnetic simulation of the HSC cavity is simulated in over 5 million meshes.

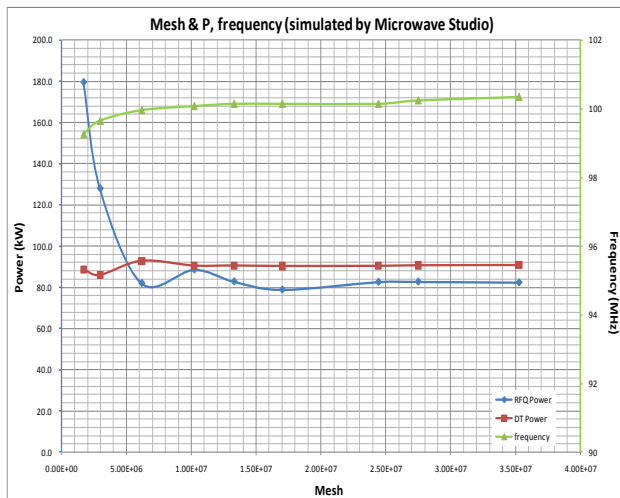

Fig.6: simulated results of relation of mesh and power & frequency.

Challenging Simulation for Integral Cutting Method and RFQ Electrode Design

For adopting 5-axil NC machine to cut the integral main frame which include all DT, all stems and all ridges in DT side and RFQ side, the 4 rods were rotated 45 degrees for easy to cutting-fabricate electrode in RFQ side and easy to screw the 4 rods. But according to cavity simulation, this rotated structure is easy to destroy the balance distribution of electric field between rods. Shown as Fig.7, both the electric field distribution in horizontal rod gap and vertical rod gap are different to original distribution in rotated structure. It could be considered that this rotated structure is unfit to ions acceleration.

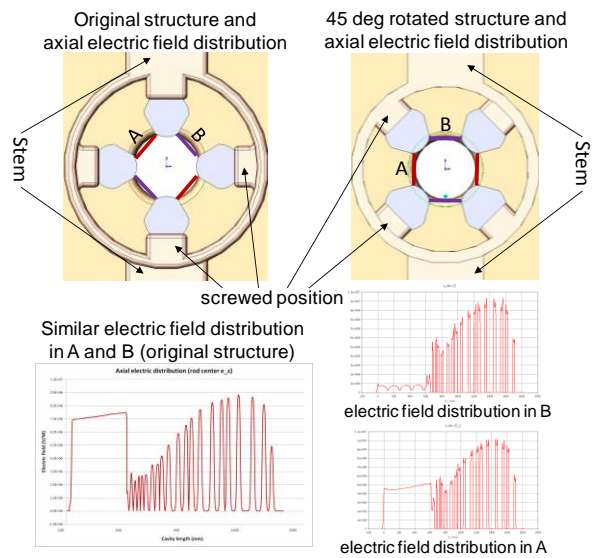

Fig.7: electric field distribution in rotated structure and original structure. It is easy to conclude that the rotated structure is an unsuitable for ions acceleration.

For abandoning the rotated structure and avoiding discharge, the electrodes in RFQ have been redesigned to square structure with two wings shown as Fig.8.

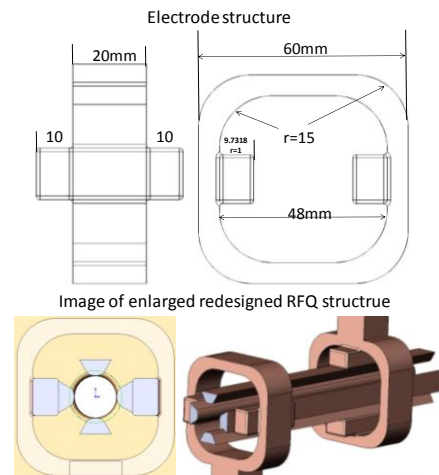

Fig.8: redesigned electrode structure.

SUMMARIES AND FUTURE PLAN

We have studied a HSC type linac that is a practical and efficient method to accelerate high intense ion beam. In this work, we discussed the beam matching designs for reducing the concentrated electric field distribution and investigated relation of mesh and power & frequency. And the electrodes in RFQ side were also redesigned. For the following step, after finishing the designs and simulations of final HSC cavity, the actual HSC linac will be fabricated and tested by proton.

REFERENCES

- [1] T. Ito, L. Lu, *et al.*, NIMB, B 261 (2007) 17-20.
- [2] T. Hattori, L. Lu, *et al.*, LINAC08, MOP059.
- [3] K. R. Crandall, *et al.*, LA-UR-96-1836 (2005)

