

THE RF SYSTEM FOR THE RCNP RING CYCLOTRON

I. Miura, T. Saito, M. Uraki and A. Shimizu
 Research Center for Nuclear Physics, Osaka University
 Mihogaoka 10-1, Ibaraki, Osaka 567, Japan

and

Y. Kumata, Y. Touchi and K. Uno
 Accelerator Business Center, Technical Department, Sumitomo Heavy Industries Ltd.
 Niihama, Ehime 792, Japan

Abstract

The RF system for the RCNP ring cyclotron consists of three single gap acceleration cavities and a single gap flat-topping cavity. Frequency range of the acceleration system is 30~52 MHz and harmonic numbers of accelerations are 6, 10, 12 and 18. Third harmonic of the acceleration frequency is used in flat-topping system.

Introduction

The RCNP ring cyclotron¹⁾ is an energy quadrupole of the present RCNP AVF cyclotron. The injection and the extraction radii of the ring cyclotron are 2.0 m and 4.0 m, respectively. The extraction radius of the AVF cyclotron is 1.0 m. With this accelerator system, beams of p, d, ³He, alpha and light-heavy ions will be accelerated up to 400, 200, 510, 400 and 400-Q²/A MeV, respectively.

Fig. 1 shows relation between orbital frequencies and acceleration frequencies in the present AVF cyclotron and the ring cyclotron for various ions and energies. The harmonic numbers of acceleration are also shown. Frequency range of the acceleration system is 30~52 MHz and harmonic numbers of acceleration is 6, 10, 12 and 18. Third harmonic of the acceleration frequency is used in flat-topping system. Characteristics of the acceleration system and the flat-topping system are summarized in Table 1. Three acceleration cavities and one flat-topping cavity are used in the ring cyclotron²⁾. These resonators are variable frequency single gap cavities. A new type variable frequency resonator was developed for the acceleration cavity. Excellent phase stability is required to get high quality beam with flat-topping. Preliminary study of a phase regulation system has been made. 250 kW RF power amplifiers for the acceleration cavities were made and have been tested by using a dummy load. Three RF power amplifiers for the acceleration cavities, one of the three acceleration cavities and the flat-topping cavity were delivered. Preliminary measurements of electrical characteristics of the cavities have been done.

Table 1
 Characteristics of the RF system

	acceleration system	flat-topping system
RF frequency	30~52 MHz	90~155 MHz
Harmonic Number	6,10,12,18	
Number of cavities	3	1
RF peak voltage	500 kV	170 kV
RF voltage stability	10 ⁻⁴	10 ⁻³
RF phase excursion	±0.1°	±0.3°
RF power output	250 kW/cavity	45 kW
1st stage TR wideband	500 W	500 W
2nd stage	RS2012CJ	4CX3500A
final grounded grid	RS2042SK	4CW 50,000E
Resonator	single gap	single gap
Power feeder	inductive coupling	inductive coupling
Beam aperture	30mm×2310mm	30mm×2130mm
Acceleration gap	200~300mm	50mm

Synchronized operation

Fig. 2 shows a block diagram of the RF system. Acceleration frequency of the injector cyclotron, generated by a frequency synthesizer, is used as clock signal of the RF system.

The clock signal is converted to the acceleration frequency of the ring cyclotron by a frequency multiplier. The signal generator and divider block generates flat-topping frequency, buncher frequency, local frequencies and intermediate frequency by using two crystal-oscillators (120 MHz and 119.545 MHz) and double-balanced mixer. Intermediate frequency is used in phase control systems and auto tuning servo systems.

Each RF power is feed through variable length coaxial cable (50 Ω) coupled to the cavity with variable coupling loop. The forward and the reverse power signals are used for automatic tuning of the cavity. Relative-phase stability between the cavities should be better than ±0.1° to accelerate 400 MeV proton with good energy resolution (< 10⁻⁴).

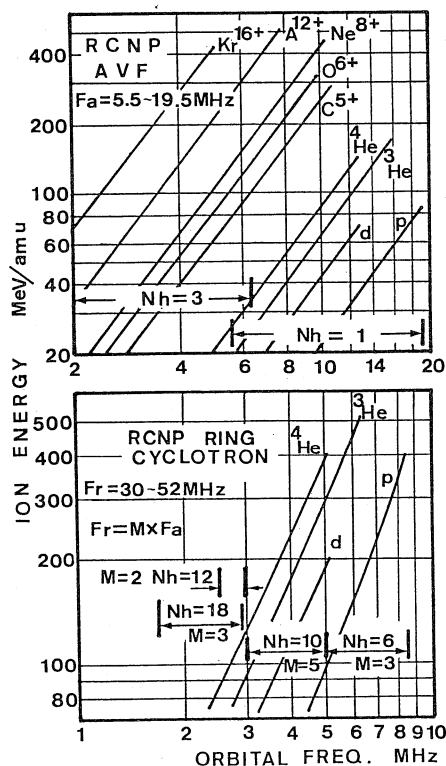

Fig. 1 Orbital frequencies, acceleration frequencies and harmonic numbers of acceleration in the present AVF cyclotron and the Ring Cyclotron M is ratio of the RF frequency of the Ring cyclotron to the AVF cyclotron.

A long term phase excursion of RF power amplifier system was measured on the present AVF cyclotron. The result shows that the phase excursion is less than $\pm 1^\circ$ without phase stabilizing loop. Main source of phase drift comes from wideband amplifier.

If high frequency signals propagate through long line, thermal effect on the propagation velocity is not negligible to get phase stability better than $\pm 0.1^\circ$. Thermal coefficients of propagation velocities were measured for various coaxial cables. The results for polyethylene cable, polytetrafluorethylene cable and foaming polystyrol cable are shown in Fig. 3. Foaming polystyrol cable has very small coefficient for wide temperature range. Polyethylene cable is suitable for air-conditioned room and polytetrafluorethylene cable is much suitable for delay-line in temperature-stabilized oven.

A block diagram of the phase stabilizing loop is also shown in Fig. 2. A and B are phase reference points and the RF phase at C should be stabilized. CD, BE, AH and FG are the propagation times. The stabilized RF phase (Φ) of the cavity voltage at C is as follows.

$$\Phi = 2\pi F_c(CD-BE) + 2\pi F_{im}(FG+BE-AH) + \Phi_0 \quad (1)$$

$$F_c \gg F_{im} \quad (2)$$

$$F_{im} = \text{constant} \quad (3)$$

Where F_c and F_{im} are cavity and intermediate frequency respectively. In the following condition, Φ is independent on the cavity frequency F_c .

$$CD = BE \quad (4)$$

The main term of the thermal effect on propagation time can be canceled also by this condition. The thermal effect for the second term also can be canceled by the following condition.

$$AH = FG + BE \quad (5)$$

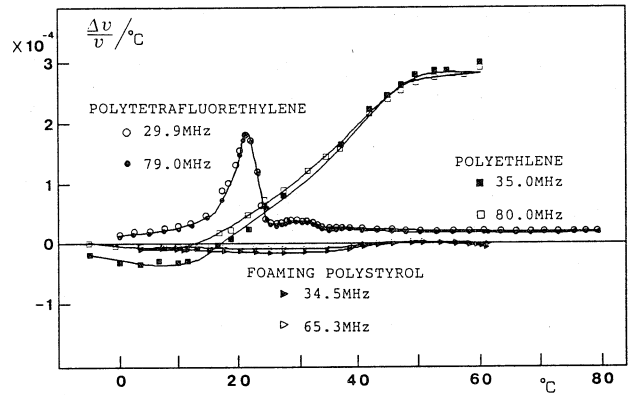

Fig. 3 Thermal coefficient of propagation velocities in coaxial cables.

The cavity phase Φ can be controlled by using temperature-stabilized variable-length delay-cable added to pass AH or FG for the intermediate frequency 0.455 MHz.

Acceleration cavity

The cavity is variable frequency single gap resonator. Fig. 4 shows schematic drawing of the acceleration cavity. The resonant frequency is varied by rotating a pair of tuning plates. The plates are electrically connected to a wall of the cavity through current-carrying hinges. Maximum current density at the copper plate of the hinge is 20 A/cm. The copper plate proved to bear more than 10^5 cycles of 90° bending test at room temperature. The fine tuning is done by changing the inductance with two cylindrical trimmers.

Cooling water of the plates is fed through the tuner shafts. The walls of the cavity are made of stainless steel with water cooled copper lining. Acceleration electrodes are made of copper. The copper skin of the capacitive tuning plates are sustained by aluminum frameworks. The cavity is evacuated by 20 inch cryopump. The cavities are able to be withdrawn easily along rails for the maintenance. The interface surfaces between magnet chambers and the cavities are sealed by pneumatic expansion seals.³⁾

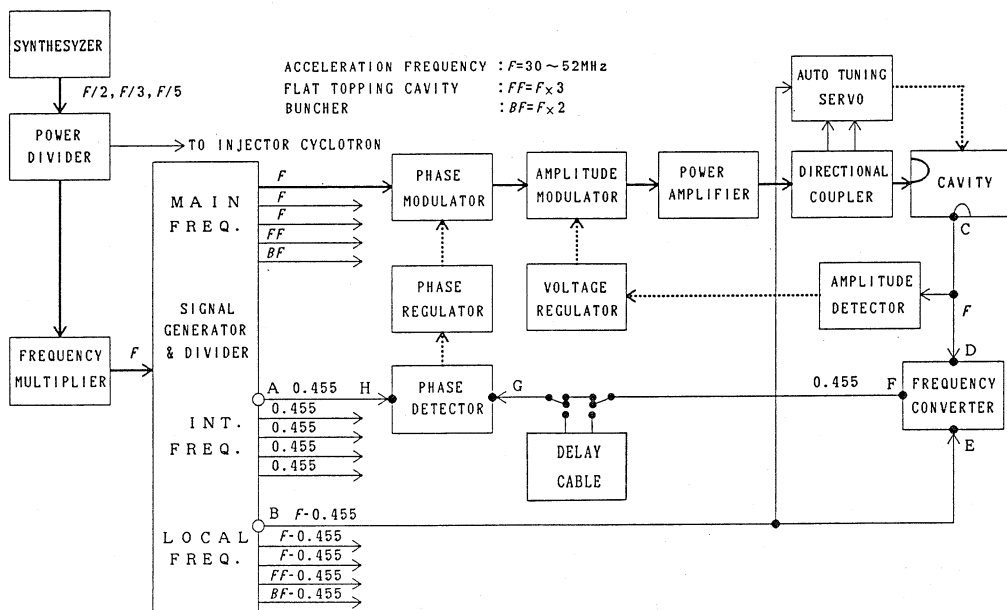

Fig. 2 Block diagram of the RF system.

The side walls of the cavity is not strong member to support atmospheric pressure. The support for the atmospheric pressure is provided by the neighboring magnet chambers. Quick disconnectable clumps are equipped to unite the cavity with the magnet chambers.

Fig. 5 shows distributions of acceleration voltage along the acceleration gap measured with the model cavity. The voltages are normalized to the maximum voltage. Radially increasing voltage distributions are obtained. Voltage distributions show a little frequency dependence.

Fig. 6 shows measured Q values and shunt impedance of the acceleration cavity. The shunt impedance for 30 MHz and 52 MHz are 450 k Ω and 1450 k Ω , respectively. Good matching between the 50 Ω RF power cable and the cavity was obtained with small loop of the coupling.

Flat-topping cavity

A single gap resonator is also used for the flat-topping cavity. Fig. 7 is schematic drawing of the flat-topping cavity. The mechanical structure of the cavity wall is similar to that of the acceleration cavity. Resonant frequency is changed by sliding the upper and lower walls of the cavity. The sliding walls have silver contacts. The contacts are pressed to the side walls by pneumatic pressure. Each sliding wall is supported by two rods which have piping for cooling water and pneumatic pressure.

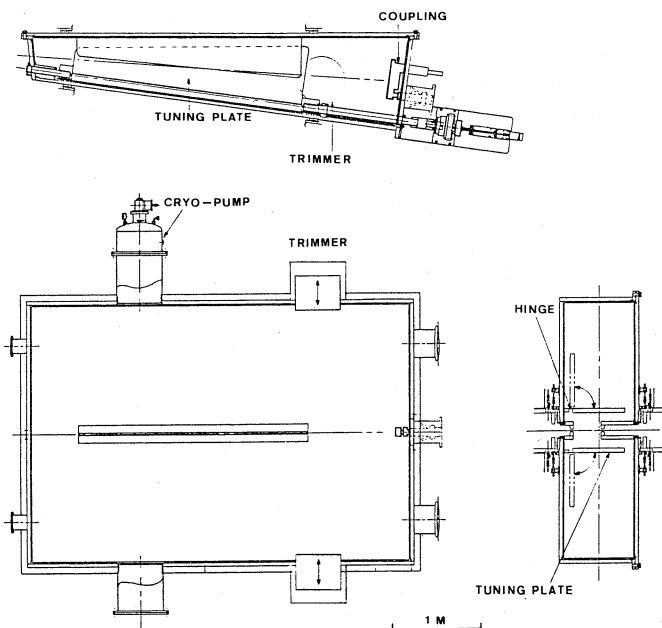

Fig. 4 Schematic drawing of the acceleration cavity.

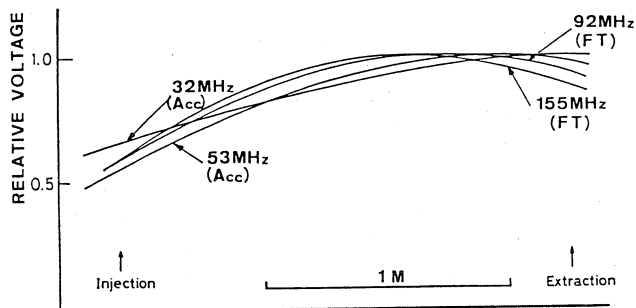

Fig. 5 Distributions of acceleration voltage along the acceleration gap measured with the model cavities.

The flat-topping cavity is designed to get similar voltage distributions to those of the acceleration cavity. Fig. 4 shows distribution of flat-topping voltage. The frequency range of the flat-topping cavity is higher than the cutoff frequency of RF leakage through the beam aperture. The leakage signal might disturb beam phase probes. A pair of pick-up electrode is prepared to detect the vertical component of the RF leakage field. The leakage will be minimized by correcting the position of the sliding walls.

Preliminary measurements of electrical characteristics of the flat-topping cavity have been done. The measured Q values and shunt impedance of the cavity for 157 MHz are 1.7×10^4 and 350 k Ω respectively.

For the flat-topping cavity, large loop is need to get proper coupling. Self-inductance of the coupling loop for the flat-topping cavity is 0.2 μ H. The mutual-inductance can be adjusted by rotating the loop. The self-inductance of the loop makes very bad effect for high frequency. However a very good matching condition between the power cable and the cavity achieved for 157 MHz by using a series capacity 5 pF. The SWR was less than 1.1.

References

- 1) I. Miura et al., Presented at this symposium.
- 2) T. Saito et al., Proc. 12th Int. Conf. on Cyclotrons and their Application, Berlin (1989).
- 3) A. Shimizu et al., Presented at this symposium.

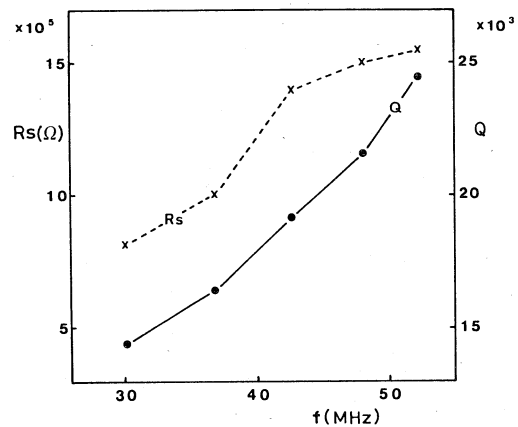

Fig. 6 Measured Q values and shunt impedance of the acceleration cavity.

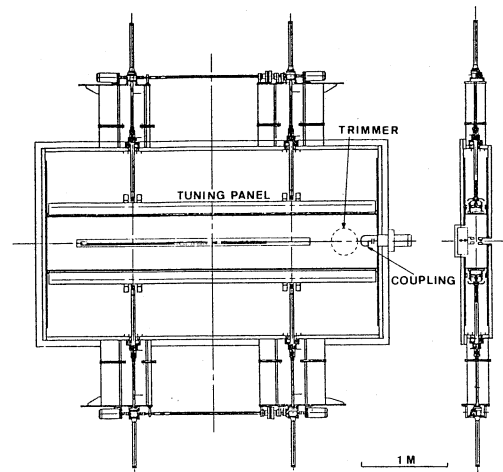

Fig. 7 Schematic drawing of the flat-topping cavity.