

STUDY OF THE INJECTION DEVICES FOR THE STORAGE RING OF SPRING-8

H.Miyade, H.Tanaka, J.Ohnishi, and S.Motonaga
RIKEN-JAERI Synchrotron Radiation Facility Design Team
2-28-8 Honkomagome, Bunkyo-ku, Tokyo 113 Japan

Abstract

The injection devices of the storage ring of SPring-8 contain three septum magnets and four bump magnets.

The first septum magnet and the second have the same specifications. These are operated with the direct current. The third is the passive type and is operated with the pulsed current. When the pulse width is 40μs, it is expected that the stray field is ~40G.m on the bump orbit.

Four bump magnets are operated by the pulsed current and the pulse width is 4μs. The core is made of ferrite and the vacuum chamber is made of ceramic.

Requirements from beam dynamics

The storage ring of SPring-8 is a third-generation light source. A ring of this kind is characterized by quite low emittance (about 5 nm.rad in storage ring of SPring-8) compared with the previous storage ring of same circumference and energy, and also characterized by so many dispersion free straight sections for the insertion devices. These characteristics make the quadrupole magnets markedly strong and the chromaticities large. In addition, the large chromaticities introduce the strong sextupole magnets for compensation of them. This mechanism naturally makes the beams in the third-generation light source unstable at a large oscillation amplitude and sensitive to magnet errors.

In spite of many studies, the dynamic aperture of the storage ring of SPring-8 is now about 10 mm for horizontal plane at worst case in presence of practical errors.¹⁾ In order to achieve the high injection efficiency (≥ 50 %) for this delicate ring, the tentative tolerance shown in Table 1 are determined.²⁾

Septum magnet

The beam from the synchrotron is injected into the storage ring at one of the 6.5m long straight sections. Figure 1 shows the beam injection section, and Table 2 shows the distance and the angle of the injection orbit.

Two septum magnets in the upper stream are the same. The cross sectional view at the position E in Fig.1 is shown in Fig.2, and the main parameters of the magnets are summarized in Table 3. To construct the magnets easily they have straight axes. Figure 3 shows the stray field calculated in the geometry of Fig.2. The result is that the stray field on the bump orbit is 2.6G and that on the reference orbit is 1.6G.

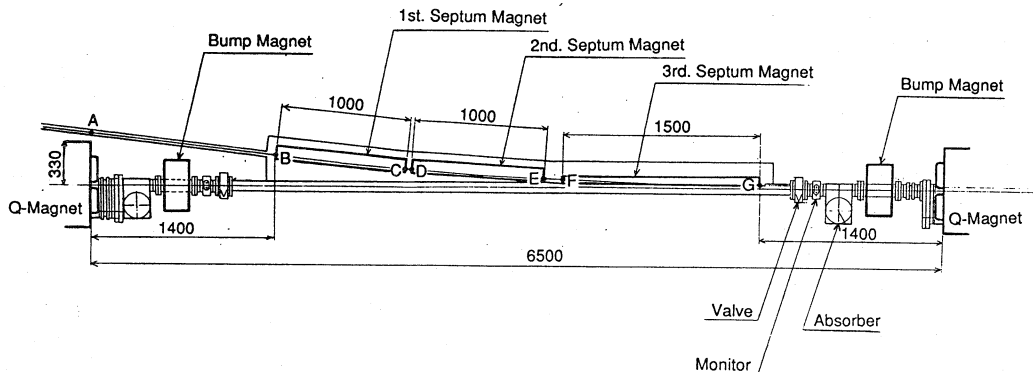

Fig.1 Schematic diagram of the injection section.

Table 1
Tentative Tolerance for Injection Errors

Item	Tolerance
Injection Trajectory Errors :	Angle 0.2 mrad Position 0.2 mm
Twiss Parameter Matching Errors :	$\beta \pm 25 \%$ $\alpha \pm 0.3$
Septum Stray Field Error :	≤ 30 G.m on Bump Orbit ≤ 1 G.m on Reference Orbit
Bump Magnet Residual Field Error ^{*)} :	Damping Coefficient $\leq 10^5$ sec ⁻¹ in the case of Amplitude Coefficient $\leq 5 \%$ Damping Coefficient $\leq 10^7$ sec ⁻¹ in the case of Amplitude Coefficient $\leq 50 \%$

*) $B_{\text{residual}} = A \times F_0 \times \text{Exp}(-Bt) \times \text{Sin}(\omega t)$
 F_0 : Design Magnetic Field Strength
 A : Amplitude Coefficient (-)
 B : Damping Coefficient (sec⁻¹)

Table 2
Distance from the reference orbit and Angle of the injection orbit.

Position	Distance (mm)	Angle (deg)
A	394.9	6.6
B	232.9	6.6
C	135.3	4.6
D	131.3	4.6
E	68.5	2.6
F	61.7	2.6
G	27.65	0.0

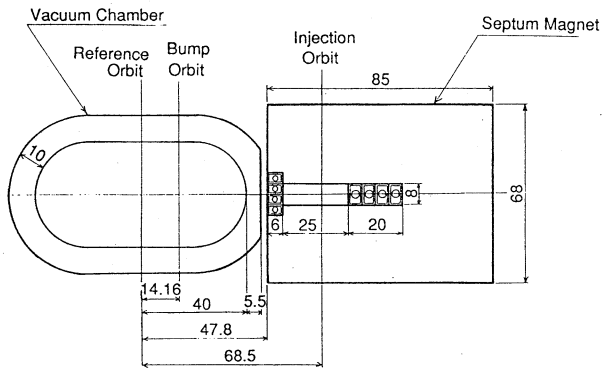

Fig. 2
Cross sectional view of the second septum magnet.

Table 3
Parameters of the septum magnets.

	1st, 2nd	3rd
Length (m)	1	1.5
Bending Angle (deg)	2.0	2.6
Peak Field (T)	0.931	0.807
Number of Turns	4	1
Inductance (μH)	70.4	2.64
Current Waveform	DC	Half Sine-Wave
Peak Current (A)	1480	6420
Pulse Width (μs)		40
Repetition Rate (Hz)		60

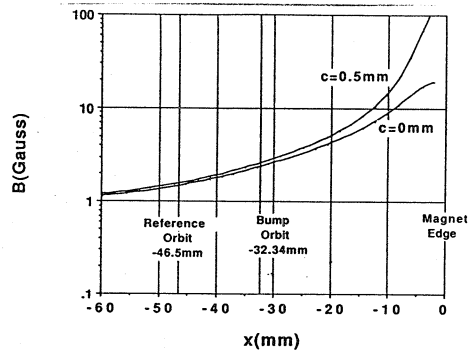

Fig. 3
Stray field for the second septum magnet.
"c" means the clearance between the coil and the core.

Figure 4 shows the cross sectional view at the position G in Fig.1 and the main parameters of the third septum magnet are summarized in Table 3. The magnet has a bend along the injection orbit to thicken the septum gradually. The core consists of 0.1mm thick silicon steel lamination.

The third septum magnet must be installed very close to the reference orbit; the minimum septum thickness is 1.5mm. Furthermore it is required to be installed out of the vacuum chamber of the storage ring. There is no coil space except the back leg of the magnet. However such a configuration makes the stray field increase extremely. Then the passive type has been adopted; when the magnet is operated with the pulsed current, the eddy current is generated in the septum wall and then the magnetic field caused by the eddy current suppresses the stray field.³⁾

Figure 5 is the result of the dynamic analysis of the magnetic field in the geometry of Fig.4. In this analysis the pulse width, the peak current, the

current wave form, and the material of the septum are 40μs, 6600A, half sine wave, and aluminum respectively.

From the analysis it is found that the stray field reaches the maximum at ~40μs. At the time the stray field is ~160G on the bump orbit. Considering the septum thickening gradually, it is expected that the stray field decreases according to the following equation,

$$B \propto \exp(-t/\delta)$$

where B, t, and δ are the stray field, the thickness of the septum, and the skin depth of the material of the septum. Using the equation and integrating the stray field along the bump orbit, the total stray field effect becomes ~40G.m on the bump orbit. This value is little larger than the tolerance. In order to reduce the stray field it is considered that the material of the septum is changed into copper and the pulse width is reduced.

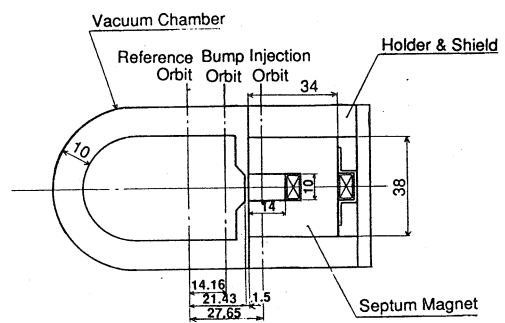

Fig. 4
Cross sectional view of the third septum magnet.

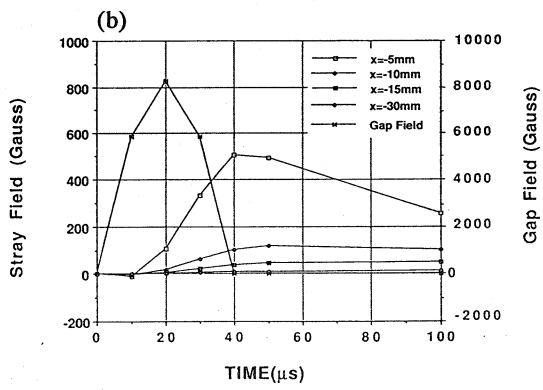
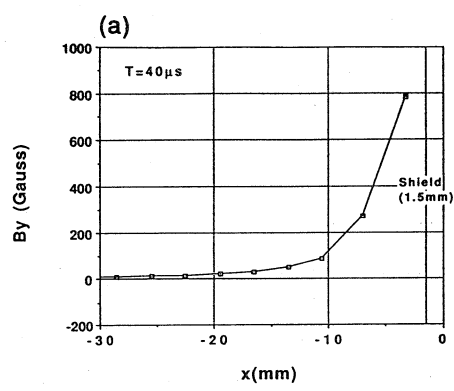

Fig. 5
Stray field for the third septum magnet.
(a) Dependence on the distance
(b) Dependence on the time

Bump magnet

Figure 6 shows the arrangement of the bump magnets. There are two types of bump magnets; one type magnets are installed in the both ends of the injection section and the other type magnets are beside the bending magnets. The cross sectional view and the main parameters of the bump magnets are shown in Fig.7 and Table 4 respectively. After the beam injection into the storage ring the magnetic fields of the bump magnets must be vanished in one turn. So the pulse width has been set 4 μ s. To avoid the generation of the eddy current the core is made of ferrite and the vacuum chamber is made of ceramic.

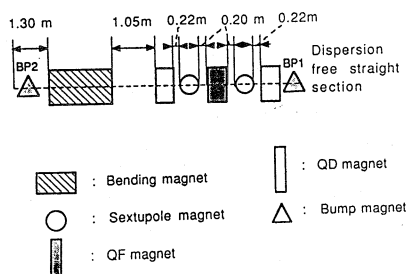

Fig.6 Arrangement of the bump magnets

Power supply

The first and the second septum magnets are operated with the direct current and are connected in series to the power supply. The stability is required to be less than 0.01%. This comes from that the angle error of the injection beam at the injection point is required to be less than 0.2mrad.

The third septum magnet is operated with the pulse of 40 μ s wide produced by a capacitor discharge power supply.

For the bump magnets the power supplies are also capacitor discharge types. The pulse width is 4 μ s. To satisfy the tolerance the undershooting current has been less than 5%.

The parameters of the power supplies are summarized in Table 5.

Table 5
Parameters of Power Supplies.

	Septum Magnet		Bump Magnet	
	1st,2nd	3rd	BP1	BP2
Load (μ H)	70.4	2.6	0.45	0.91
Waveform (*)	DC	HS	HS	HS
Peak Current (A)	1480	6420	3830	7450
Pulse Width (μ s)	—	40 \pm 10%	4 \pm 10%	4 \pm 10%
Jitter (ns)	—	<50	<5	<5
Undershooting (%)	—	<5	<5	<5
Stability (%)	<0.01	<0.1	<0.1	<0.1
Repetition Rate (Hz)	—	60	60	60

(*) DC:Direct Current HS:Half Sine Wave

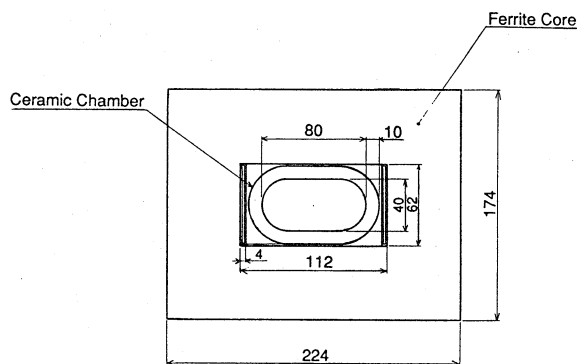

Fig.7 Cross sectional view of the bump magnet.

Table 4
Parameters of the bump magnets.

	BP1	BP2
Length (mm)	200	400
Bending Angle (mrad.)	0.5831	2.26
Peak Field (T)	0.0777	0.151
Inductance (μ H)	0.45	0.91
Current Waveform	Half-Sine	Half-Sine
Peak Current (A)	3830	7450
Pulse Width (μ s)	4	4
Repetition Rate (Hz)	60	60

References

- 1) H.Tanaka, R.Nagaoka, K.Yoshida, K.Tsumaki, and M.Hara, RIKEN Accel. Prog. Rep., 22, P235 (1988).
- 2) H.Tanaka, R.Nagaoka, K.Tsumaki, K.Yoshida in preparation.
- 3) N. Marks and M. W. Poole, IEEE trans. on Mag. Vol.MAG-17, No.5, P1579 (1981)