

## CONTROL SYSTEM FOR HIMAC INJECTOR

T. Kohno, S. Yamada, H. Ogawa, Y. Sato, K. Sato, A. Itano,  
M. Kanazawa, K. Noda, K. Kawachi, M. Maruyama\*, K. Aoki\*\*,  
S. Hara\*, O. Morishita\* and Y. Hirao

National Institute of Radiological Sciences  
4-9-1 Anagawa, Chiba-shi, Chiba 260, Japan

### Abstract

A control system for HIMAC injector has been designed. The system consists of three mini-computers and many intelligent device controllers. The device controller is a single-board computer with a real time monitor and is installed in each device. Almost man-machine interactions for an operation of the injector system are performed by touch panels and rotary encoders.

### Introduction

HIMAC (Heavy Ion Medical Accelerator in Chiba) is a heavy-ion synchrotron complex dedicated to the medical use<sup>1)</sup>. It is roughly divided into four sub-systems, that is, an injector system, a two-synchrotron ring system, a high-energy beam delivery system and an irradiation system. The total control system for HIMAC has a hierarchical structure which consists of a central computer and system control computers corresponding to the sub-systems mentioned above. All computers are connected through a local area network Ethernet as shown in Fig.1.

The central computer has charge of a global control and a supervision of the whole system of HIMAC including an interlock system for a radiation safety. The central computer will be also linked by hardware and/or software to the computers controlling the other equipments in this facility such as a water cooling system, an air-conditioning system and a radiation

safety system.

On the other hand the control computer of each sub-system is used for the control of individual devices and the sequence controls of device groups in the sub-system. Since the sub-systems of HIMAC are designed and manufactured by different companies, respectively, computers and interfaces used in the sub-systems are different. Therefore each sub-system is designed to be operated independently as far as possible by reducing the data to be transferred between the different sub-systems. And the items in hardware and software concerned with a man-machine interface must be standardized so that operators can operate as if all control systems were the same. This report will present an overview of the control system for HIMAC injector.

### System Configuration

The injector system consists of two types of ion sources and linacs<sup>2)</sup>. A PIG source is used mainly for lighter ions, whereas an ECR source is expected to improve heavier ion capabilities of HIMAC. The ions from these sources are accelerated up to 6 MeV/u through an RFQ and Alvarez linacs. All devices in the injector system are divided into several groups. The examples of the groups are the "PIG" group, the "ECR" group, the "LINAC" group, the "VACUUM SYSTEM" group and the "TIMING SYSTEM" group. Furthermore each group is divided into several blocks. These groups and blocks are the units for the sequence controls.

- MAIN : Central Computer System
- SYN : Synchrotron Sub-System
- HEBT : High-Energy Beam Delivery Sub-System
- IRR : Irradiation Sub-System
- SCU : System Control Unit
- GCU : Group Control Unit
- MTB : Message Tree Brancher
- UDC : Universal Device Controller

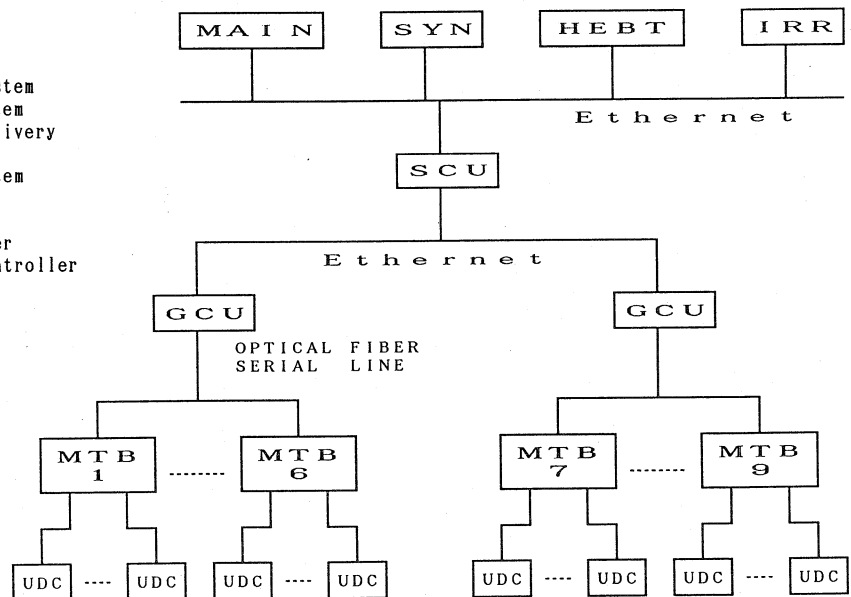

\* Sumitomo Heavy Industries, Ltd.,  
Niihama-shi, Ehime 792, Japan  
\*\* Sumitomo Heavy Industries, Ltd.,  
Tanashi-shi, Tokyo 188, Japan

Fig.1 Schematic description of the control system for HIMAC. Lower part of the figure is for the injector system.

The control system for the injector consists of three mini-computers and many controllers in three levels as shown in Fig.1. A UDC (Universal Device Controller) in the figure is an intelligent device controller installed in each device and its detail is described in the next section. The control functions of a main computer (SCU : System Control Unit) and two sub-computers (GCU : Group Control Unit) are as follows.

### 1) SCU (System Control Unit)

The SCU is a 32-bit mini-computer and controls the total system including a man-machine interface for operators and a communication interface to the central computer and the GCU's. As the control system for the injector has a hierarchical structure by distributing three mini-computers and many controllers, the main function of the SCU is a global control of the whole system by sending macro-commands to two GCU's, for example, to start up the system, or to set operation parameters to devices. The SCU controls start-up and shut-down sequences for the whole system, each group and each block. Of course the SCU can control individual devices.

It is also important role for the SCU to manage operation parameter files and a data base for all devices in the injector system, because the initial parameters for the devices are set at the beginning of the operation from the parameter file selected by an operator. The SCU is connected to the central computer through Ethernet. The SCU receives macro-commands from the central computer and sends status of the injector system to the central computer. All kinds of operations at an operator console are under supervision of the SCU through the man-machine interface.

### 2) GCU (Group Control Unit)

The GCU is a 32-bit computer and connected to the SCU through Ethernet. The GCU is also connected to the UDC's through optical fiber serial lines. The GCU has charge of the controls of individual devices and the sequence controls of device groups according to the instructions from the SCU. Since the GCU samples status and actual values of device parameters periodically through the UDC's, if a fault is happened in any device, the GCU sends an information about the fault to the SCU and the fault sequence is automatically carried out.

A local console is available at the GCU level. This console is used mainly for the local operation of the ion sources in the case of a maintenance, starting up, etc.. For example, when the PIG source is operated at the console of the SCU using a parameter file, we can operate the ECR source independently at the local console. The GCU has a real time operating system, but has no magnetic disk. Programs and operation parameters for devices are down-line loaded at the starting time of the control system.

### Interface System

In the injector system an intelligent device controller called a UDC is used for an interface between a GCU and a device. The UDC has been developed by Sumitomo Heavy Industries as a device controller in a distributed control network system shown in Fig.2. The MTC (Message Tree Communicator) is the host station connected to the bus line of the host computer (GCU). Each UDC is connected to the GCU through a distributor of optical signals (MTB : Message Tree Brancher) and an optical fiber serial line with 375 kbps transmission speed. The MTC sends Order Messages to the UDC assigned by the host computer and receives Status Messages from all UDC's every 100 ms.

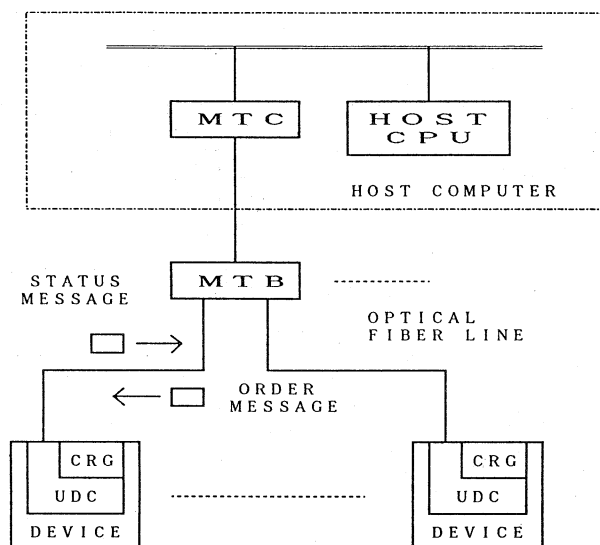

Fig.2 Distributed control network system and message flow in the control system for the injector.

The UDC is installed in each device : a power supply, a profile monitor, a stepping motor controller and a vacuum system. The UDC controls a device locally, and consequently the load of a higher level computer is reduced. The function common to all UDC's is a communication to the host computer. The other functions peculiar to each UDC are an interlock and a sequence control of a device, a periodic data sampling, a stability check by comparison between preset values and measured actual values, etc..

### 1) Hardware of the UDC

The UDC is a single-board computer with 32-bit parallel input, 32-bit parallel output and 16-bit bidirectional parallel input/output ports and related interfaces. The UDC also has an Intel SBX-bus connector for an extension of I/O. The microprocessor chip used in the UDC is an 8-bit 8344 with 48 kbyte ROM and 16 kbyte RAM. The 8344 chip includes an 8051 microcontroller, a serial interface unit (SIU) which supports an SDLC protocol by hardware and a 192 byte dual-port RAM. The dual-port RAM is used as a work area for the CPU and the communication area between the CPU and the SIU.

### 2) Software of the UDC

The UDC must deal with several tasks in real time such as a device control, a communication to the MTC and a local operation of a device. A real-time and multi-task monitor UDC44 has been developed for this purpose. The UDC44 contains a kernel, a basic input/output system (BIOS) and a serial interface unit (SIU) handler. The software of the UDC consists of the monitor UDC44 common to all UDC's and an application program peculiar to each UDC. The kernel starting every 1 ms can manage 8 tasks in the maximum simultaneously including the SIU handler. The SIU handler is a task for a communication between the UDC and the host computer. It always has a second priority in all tasks and is generated only when the UDC receives the data from the host computer. The BIOS manages a CRG and input, output ports of the UDC.

The CRG (Communication Register) is a 128 byte area in the RAM inside the UDC. The meaning of each bit or byte in the CRG is determined uniquely in each

Table 1

Main menus of CRT's at operator console

14-inch CRT (left)	14-inch CRT (right)	20-inch CRT (left)	20-inch CRT (right)
BEAM ADJUST (fixed)	FILE SELECT PARAMETER SET UP BEAM ADJUST TREND SELECT DEVICE OPERATION PARAMETER FILE PRINT	PARAMETER LIST STATUS LIST NOT READY LIST FAULT LIST ALARM LIST TREND PARAMETER BEAM MONITOR PARAMETER FILE LIST UDC STATUS	VACUUM STATUS DEVICE STATUS

UDC. Instructions, data necessary to the control and status of the device are written there. The host computer also has an equivalent image of the CRG. Since the application programs of the host computer and of the UDC are linked directly each other through the CRG, a user doesn't have to be conscious of the hardware between them.

#### Operator Console

An operator console has two 20-inch CRT's with touch panels, two 14-inch CRT's with touch panels and three rotary encoders. Almost man-machine interactions are performed by the touch panels and the rotary encoders. The functions of each CRT are listed in Table 1.

The left 14-inch CRT is fixed to use for an adjustment of device parameters and the right one is used for a device selection. The right one is also used for almost other operations. In the normal operation an operator opens the "FILE SELECT" screen at first and inputs some items to select a parameter file. The selected file is loaded to the memory of the SCU by touching the "LOAD" key of the screen. The "PARAMETER SET" screen is used to set the parameters to the devices. Three modes of start-up sequences are available: starting up the whole system as one unit, starting up each group as one unit and starting up each block as one unit. For fine adjustment of each parameter the "BEAM ADJUST" screens of both the CRT's are used. In the right "BEAM ADJUST" screen three parameters are assigned to three rotary encoders, respectively, and adjusted independently at the same time. The preset values, the actual values and the other informations about these devices are displayed in the left "BEAM ADJUST" screen. The shut-down sequences are also carried out on the "PARAMETER SET" screen.

The operator can observe the changes of device parameters on the left 20-inch CRT by sampling actual values periodically. The devices are selected and the time intervals for data sampling are set in the "TREND

SELECT" screen. The "DEVICE OPERATION" screen is used to operate an individual device independent of start-up and/or shut-down sequences for a maintenance. The usual managements for the parameter files: "COPY", "SAVE", "DELETE" and "PROTECT", are done on the "PARAMETER FILE" screen. The parameters and status of the devices can be printed out at anytime or periodically by selecting the devices and setting the time interval on the "PRINT" screen.

On the left 20-inch CRT only the "TREND PARAMETER" and the "BEAM MONITOR" screens are graphically displayed. The present status of the devices: ON/OFF, READY/NOT READY, NORMAL/FAULT and REMOTE/LOCAL, is listed on this CRT. The contents of the "PARAMETER LIST", the "STATUS LIST" and the "NOT READY LIST" screens are refreshed periodically. On the other hand the device names and the fault items on the "FAULT LIST" screen are latched until the operator resets the devices. The "DEVICE STATUS" is also displayed graphically on the right 20-inch CRT. Concerning the vacuum system the operations for all pump stations and gate valves are concentrated on this CRT and the status of the pump stations and the vacuum of the beam line are displayed graphically.

#### Acknowledgement

The authors wish to thank the staffs concerned with the HIMAC project in NIRS for their helpful discussions and advice. The authors are also grateful to the engineers of Sumitomo Heavy Industries, Ltd., Mitsubishi Electric Corp., HITACHI, Ltd. and Toshiba Corp. for their support and coworks to fix the design of the control system for HIMAC injector.

#### References

- 1) S. Yamada et al., Proc. of 6th Symp. on Accel. Sci. and Technol., Tokyo, Japan, 1987, p.33
- 2) S. Yamada et al., submitted to this symposium