

High Power Test of a Damped Cavity for High-Brilliant Synchrotron Radiation Source

T. Koseki, M. Izawa*, S. Tokumoto*, K. Shinoe, Y. Kamiya, T. Nagatsuka**,
T. Miura***, K. Sato***, T. Naba***, Y. Ohnishi*** and S. Fujii***

*Synchrotron Radiation Laboratory, The Institute for Solid State Physics (ISSP),
The University of Tokyo, Tanashi, Tokyo 188, Japan*

**Photon Factory, National Laboratory for High Energy Physics,
Tsukuba, Ibaraki 305, Japan*

*** Hitachi-Zosen Corporation, Taisyo, Osaka 551, Japan*

****Toshiba Corporation, Tsurumi, Yokohama 230, Japan*

Abstract

The high power model of the damped-cavity which being developed at ISSP and Photon Factory (PF) was fabricated. The high power conditioning of the cavity was carried out. The input power of 150 kW was obtained without any severe problems.

I. INTRODUCTION

We have developed the damped-structure RF cavity for two low emittance electron/position storage rings. One is a third-generation VUV and SX synchrotron radiation source which is a future project of the University of Tokyo. The storage ring has a beam energy of 2.0 GeV, a circumference of about 400 m, an emittance of less than 5 nm-rad [1,2]. The other is a high brilliance configuration of the PF storage ring [3]. In these storage rings, coupled-bunch instability due to higher-order modes (HOM's) in RF cavity is a serious problem when stable and high beam current is required. The damped cavity, we have studied, has large beam duct, a part of which is made of a SiC microwave absorber. The HOM's propagating out from the cavity through the beam duct are expected to be damped by the SiC part.

We fabricated two cold models of the cavity and measured their RF characteristics in low power level. As the SiC absorber, we chose CERASIC-B (made by Toshiba Ceramics Co. Ltd.) which was fabricated by sintering in an argon atmosphere under normal pressure. The low power measurement showed the SiC beam ducts strongly reduce the Q-values of HOM's in the cavity [4, 5, 6]

Table 1: Parameters of the cavity.

RF frequency	500.1 MHz
Shunt impedance	7.68 M Ω
Unloaded Q	44000
Coupling coefficient (β)	> 2
Maximum wall loss	140 kW

The design parameters of the damped-cavity are summarized in Table 1. The nominal operating voltage of the cavity system is 1.5 MV for both the PF ring and the VUV-SX ring. The number of the cavity to be installed in the storage rings is four for the PF ring and three for the VUV-SX ring. For the VUV-SX ring, the nominal gap voltage per cavity is 0.5 MV, requiring the power of about 33 kW to be dissipated in the cavity. The design of 140 kW wall loss has large safety margin and operational flexibility.

The R&D of the damped-cavity is now focusing on a high power test of the cavity. The specification of the high power model and recent status of its high power conditioning are presented here.

II. HIGH POWER MODEL

The high power model cavity was manufactured at Keihin Product Operations of Toshiba Corporation [7]. Figure 1 shows the cross sectional view of the high power model.

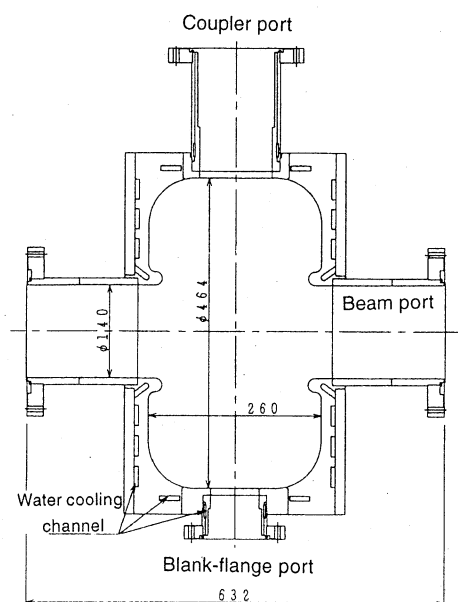

Figure 1: Cross section of the high power model.

The main part of the cavity is made of class1-OFHC copper which was treated with Hot Isostatic Press (HIP). The layout of water cooling channel is also shown in Fig. 1. The water flow of 200 *l/min* is available with a pressure drop of 4 *kgf/cm²*.

The cavity has two beam ports and four side ports for an input coupler, a tuning plunger and two blank-flanges. U-tight seal gaskets are adopted as RF contacts between the port franges and the attached equipments.

A thermal structure calculation with two dimensional mesh was carried out [7]. The analysis assumed a water flow of 140 *l/min* and inlet water temperature of 20 °C. The edge of nose cone gave the highest power density in the cavity. For 160kW total power dissipation, peak power density around the nose cone was calculated to be 30 *W/cm²*. Then, the temperature of the inner wall of the cavity was 50 - 60 °C and the edge of the nose corn was about 70 °C. The frequency shift caused by the thermal deformation was expected to be -250 kHz for the fundamental mode.

Figure 2 shows the input coupler of the cavity. The coupler was newly designed basing on the coupler which is used for the 508 MHz APS cavity of the TRISTAN ring. We changed the shape of the end of coaxial line and optimized the positions of the short plates of rectangular waveguide and coaxial line in order to obtain low-loss of 500 MHz microwave [8].

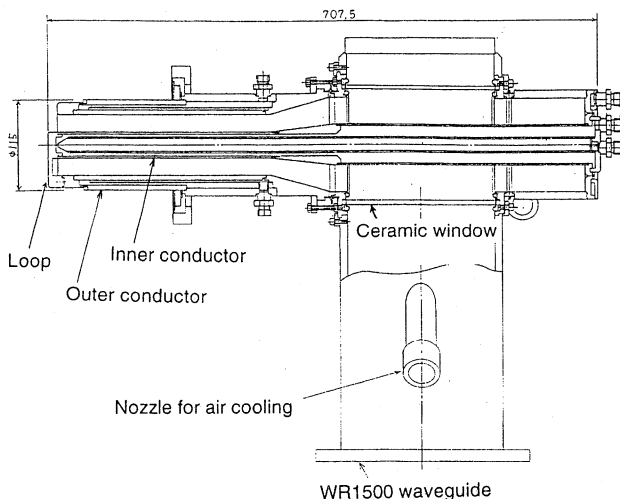

Figure 2: The newly designed input coupler.

The tuning plunger of the cavity is the same type as used in the PF cavity. The blank-flange, also called fixed tuner, is a flange with cylindrical block to pad the port of the cavity. Figure 3 shows the fixed tuner block. The center of the block was hollowed out and a viewing port was attached there. The cavity has two blank-flanges (horizontal and vertical). The blocks of the blank-flanges are projecting 10 mm from inner surface of the cavity.

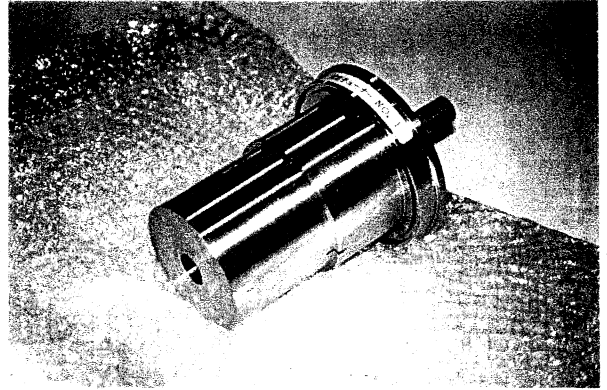

Figure 3: The fixed tuner block.

Figure 4 shows the fabricated high power model. The unloaded Q value of the accelerating mode was measured to be 40000 at 500.1 MHz. The coupling coefficient β was 2.35, while the value expected from the low-power measurement was 2.27 [6].

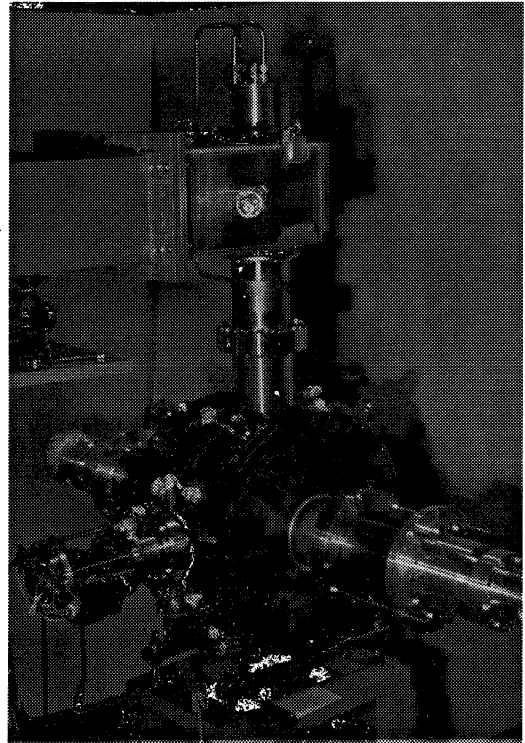

Figure 4: The high power model.

III. HIGH POWER CONDITIONING

The high power test of the cavity has been carried out at the high power test bench of the Photon Factory. SiC

beam-duct was not attached to the cavity in this test. Before the high power test, the cavity was prebaked at 150 °C for 24 hours at Keihin Product Operations of Toshiba Corporation.

In the high power test, a 300 l/sec turbo molecular pump was attached to the cavity and an ionization gauge was placed between the beam port and the turbo pump. The vacuum pressure before input RF power was 5×10^{-8} Torr.

The high power conditioning started with an input power of a few hundreds watt and the power level was slowly increased by keeping the vacuum pressure below 5×10^{-6} Torr. The reflected RF power signal was used as an interlock trigger. The tuning plunger was controlled for compensating a thermal detuning of the cavity.

After 20 hours conditioning, the input power was reached to 60 kW. The vacuum pressure was 5×10^{-8} Torr without RF power. In order to try higher power conditioning under the lower vacuum pressure, the cavity was baked at 150 °C for 24 hours. After the baking, the pressure was drop to 3×10^{-9} Torr, and then pulse conditioning at 100 kW with 10% duty was carried out for 12 hours. After that, cw conditioning was restarted.

The cavity has three viewing ports to observe discharge phenomena around input coupler, tuning plunger and nose cone. Small glowing points and occasional arcing were grow with increasing input power. However, as the high power conditioning progressed, the number of these glowing points decreased at the same level of input power.

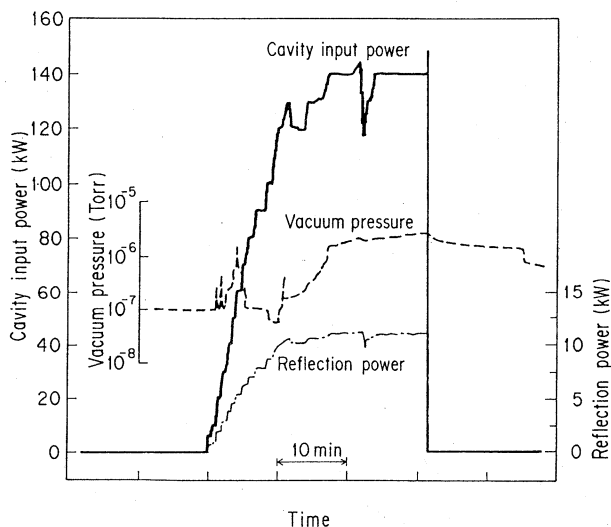

Figure 5: An example of high power test.

Up to now, total conditioning time has been 60 hours. The input power of more than 150 kW was obtained without any severe problems. Figure 5 shows an example of input power, vacuum pressure and reflection power. At an input power of 140 kW, the maximum temperatures of cavity wall was measured to be 47 °C with the cooling water of 200

l/min and 22 °C (inlet temperature). When 140kW is applied, the reflection power of 23 kW is expected from the value of coupling coefficient, $\beta = 2.35$. However, the measured reflection power was lower than the expected value. The reason of this discrepancy has not been clarified yet.

We have also fabricated the SiC beam-duct for high power test. The duct is composed of Al duct with ICF253 flanges and CERASIC-B duct which is inserted in the Al duct by the method of shrink fit. The high power test of the SiC beam-duct has been successfully carried out as described in Ref. [9].

IV. ACKNOWLEDGMENTS

We would like to thank to all staff members of SRL accelerator group and of Light Source Division of the Photon Factory for their support and useful discussions.

V. REFERENCES

- [1] Y. Kamiya *et al.*, Proc. 4th EPAC, London, 1994, p. 639.
- [2] VUV-SX Accelerator Group, "VUV-SX High Brilliance Light Source", in these proceedings.
- [3] M. Katoh *et al.*, Rev. Sci. Instrum., 66 (1995) 1892.
- [4] T. Koseki *et al.*, Proc. 4th EPAC, London, 1994, p. 2152.
- [5] T. Koseki *et al.*, Rev. Sci. Instrum., 66 (1995) 1926.
- [6] T. Koseki, M. Izawa and Y. Kamiya, "Development of a Damped Cavity with SiC Beam-Duct" to be published in Proc. 1995 PAC, Dallas, 1995.
- [7] T. Miura *et al.*, Proc. 20th linear Accelerator Meeting in Japan, 1995, p.200.
- [8] T. Nagatsuka, T. Koseki, Y. Kamiya, M. Izawa and Y. Terada, "A Design of Input Coupler for RF cavity" to be published in Proc. 1995 PAC, Dallas, 1995.
- [9] M. Izawa *et al.*, Rev. Sci. Instrum., 66 (1995) 1910