

Calibration of Beam Position Monitor for the SPring-8 Synchrotron

Tsuyoshi Aoki, Hiroto Yonehara, Hiromitsu Suzuki, Norio Tani, Hiroshi Abe
Kenji Fukami, Soichiro Hayashi, Yasuo Ueyama, Takayoshi Kaneta, Kenji Okanishi
Shigeki Ohzuchi, Takeji Miyaoka*, Kiyokazu Sato*, Eiji Toyoda*, Hiromasa Ito*
and Hideaki Yokomizo

JAERI-RIKEN SPring-8 Project Team, Kamigori, Ako-gun, Hyogo, 678-12, Japan

*Toshiba Co, 1-6, Uchisaiwai-cho, 1-chome, Chiyoda-ku, Tokyo, 100, Japan

Abstract

Beam position monitors (BPMs) for SPring-8 synchrotron were already designed and manufactured. 80-BPMs were successfully calibrated for the beam position measurement. In this paper, we introduce the structure of BPMs, the electronics of signal detection system and the calibration system, and the results of calibration are reported.

1. Introduction

Beam position monitors, which are placed in the SPring-8 booster synchrotron, are designed to measure a closed orbit distortion (COD). The BPMs are located at the upstream position of 80-quadrupole magnets. Each BPM consists of four button-type electrodes which are mounted on the wall of the vacuum chamber. The diameter of all the electrodes are 18 mm. Output signals from the electrodes of 20-BPMs are selected by PIN-diode switches, and the amplitudes of these signals are measured by the same detection system. Four detection systems are used at the same time for 80-BPMs, and the measurement time of this system is less than 30 ms.

The BPMs are calibrated by using an antenna to simulate an electron beam. The antenna is mounted on the X-Y table which is driven by the pulse motors. The 508.58 MHz signal, which is the acceleration RF in the synchrotron, is supplied from the tracking generator to the antenna. The output signals from the electrodes are measured by the spectrum analyzer. The normalized values about horizontal and vertical positions are obtained by the output signals.

2. Structure of BPM pickup

The BPM pickup consists of four button-type pickup electrodes which are attached to the SMA-type coaxial feedthroughs welded on a 80x30 mm² or 100x30 mm² racetrack-type vacuum chamber. About the electrode, the diameter is 18 mm and the capacitance with a feedthrough is about 6.8 pF.

We use three types of BPM pickups. The type 1 BPM pickups are placed at 78 positions. The horizontal distance between the center of the vacuum chamber and the electrodes is 14 mm. Figure 1 shows a cross-sectional view of the type 1 BPM pickup. The type 2 pickup has a 100x30 mm² racetrack-type vacuum chamber, and the

position of A and D electrodes are $x=24$ mm from the center of the vacuum chamber to measure the beam positions on both the reference orbit and the bump orbit for the beam extraction.

The type 3 pickup has also a 100x30 mm² vacuum chamber, and the position of the electrodes are as same as the type 1. The type 2 and the type 3 pickups are located on the straight-section where the beam extraction systems are placed.

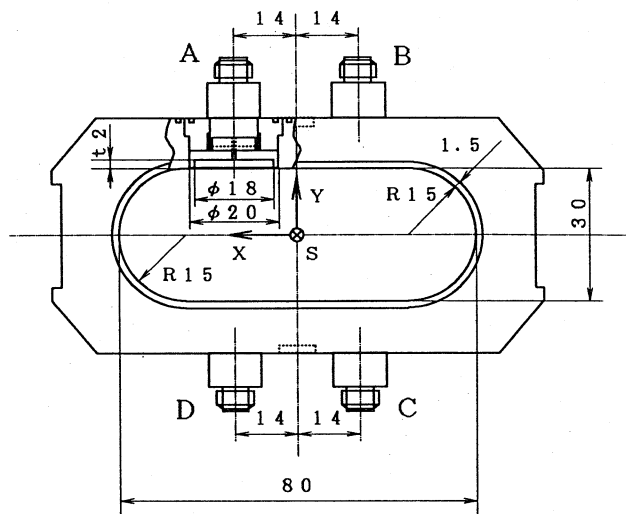

Fig. 1. The cross-sectional view of a type 1 BPM pickup

3. The Electronics of BPM

The block diagram of BPM electronics for COD measurement is shown in Fig. 2. The output signals from the BPM pickups are transmitted through the 3 dB attenuators and the coaxial cables to the electrode-selector which consists of fast PIN-diode switches and a 600-MHz low-pass filter (LPF). The switching time of the PIN-diode is less than 0.01 ms, and the duration of an one-electrode selection is 0.35 ms. The output signals from the electrode-selectors are transmitted through low-loss, high-frequency cables (WF-H50-4) to the BPM-selector.

Heterodyne circuit is used at the detection system. The 508.58 MHz signal, which frequency is the same one as the acceleration RF in the synchrotron, is transformed to a signal of 70 MHz intermediate frequency by mixing with a 438.58 MHz signal from the

local oscillator. The 70 MHz signal is converted to DC level as position signal by the synchronous detector and the 3.5 MHz LPF.

The output signals from the 80-BPM pickups are detected by four detection circuits. It is expected that the total measurement time of 80-BPMs is less than 30 ms. To measure a single-bunch beam position, the output signals from a BPM pickup are observed simultaneously by digital sampling oscilloscope (SONY Tektronix CSA803A, sampling head SD-26). Five electrode-selectors have functions to change over from COD mode to single-bunch mode.

4. Calibration System

The schematic diagram of the BPM calibration system is shown in Fig. 3. To simulate an electron beam, semi-rigid coaxial cable (UT-85) is used for an antenna and is mounted on the X-Y table which is driven to x, y and s directions by the pulse motors. The coaxial cable is inserted in the stainless steel sleeve which has 3 mm inside diameter and 5 mm outside diameter. The length of the inner conductor out of the sheathe is 50 mm.

The optical sensors are used to set the antenna at the initial position before every measurement.

The 508.58 MHz signal is amplified and is supplied to the antenna from the tracking generator output of the spectrum analyzer (HP 8560E). The output signals from the electrodes: V_A, V_B, V_C and V_D are switched by electrode-selector and are measured by the same spectrum analyzer. The X-Y table and electrode-selector are controlled by HP model 362 through the motor controller and I/O box. The offset distances between the initial position of the antenna and the center of the BPM pickups have been measured previously, and they are compensated on the software.

To simulate a distribution of electromagnetic field in the beam duct, two dummy ducts are attached both ends of the BPM pickup. To avoid a noise signal by the leaked electromagnetic wave, electromagnetic shield rubbers are stuck on the inside of dummy duct's outer sides and on the base of the antenna. At the longitudinal position more than 60 mm from the end of sleeve, electric field distribution is nearly constant. Therefore, the X-Y table is driven to s-direction that the position comes on the center of the electrodes.

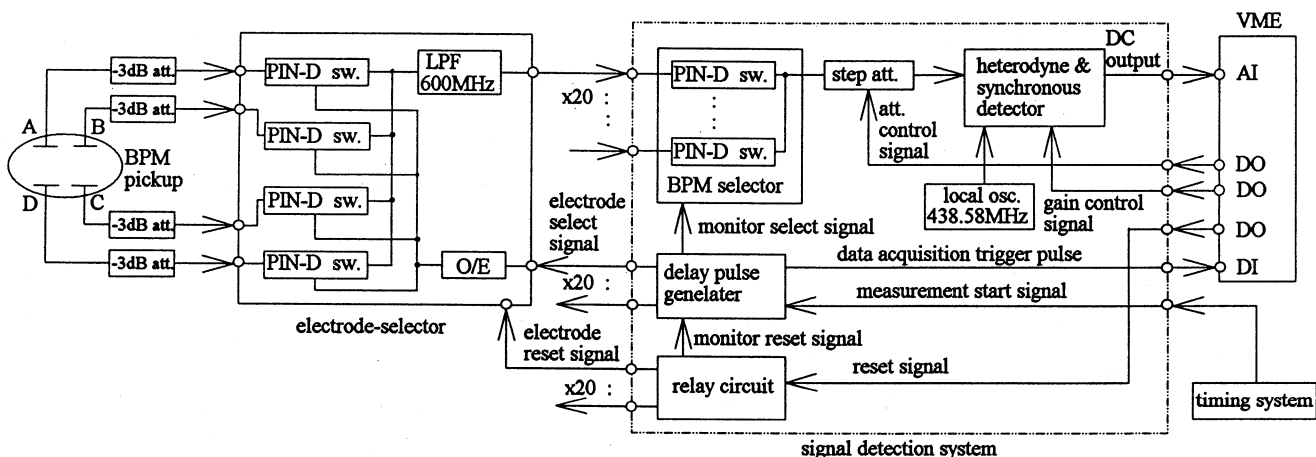

Fig. 2. The block diagram of BPM electronics for COD measurement

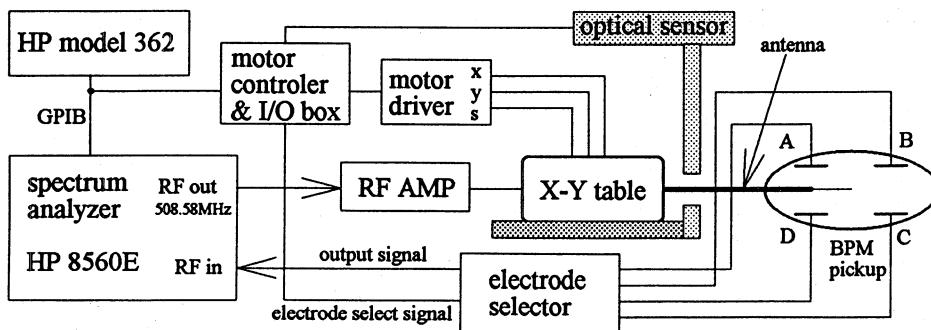

Fig. 3. The schematic diagram of BPM calibration system

5. Result of Calibration

The normalized values calculated with the output signals from electrodes:

$$H = (V_A - V_B - V_C + V_D) / (V_A + V_B + V_C + V_D) \quad \text{and}$$

$$V = (V_A + V_B - V_C - V_D) / (V_A + V_B + V_C + V_D)$$

are obtained at a position (x,y) of the antenna. Fig.4 shows an example of a result of measurement between (H,V) and (x,y) of type 1 BPM. The calibrated area of type 1 and type 3 BPM pickup is $x = \pm 15$ mm and $y = \pm 8$ mm, and type 2 is from $x = -15$ mm to $x = +25$ mm and $y = \pm 8$ mm.

calibration is about 0.1 mm. To estimate the accuracy of this calibration system, we calibrated ten times about a same BPM pickup. The deviation of the electric center, which is the position of $H=V=0$, is within 0.04 mm.

6. Conclusion

80-BPMs were successfully calibrated and the accuracy of calibration was about 0.1 mm. The BPM pickups are already welded to the beam ducts.

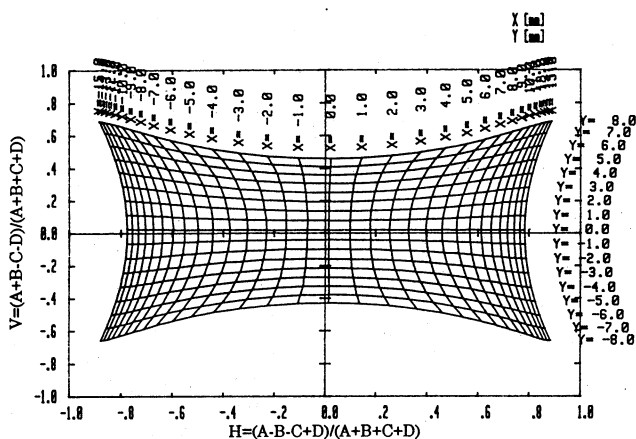

Fig. 4. An example of a result of measurement between (H,V) and (x,y) of type 1 BPM

The relationship between (x,y) and (H,V) are expressed as sextic polynomials that obtained by least square method. Figure 5 shows an example of a calibrated relationship between (x,y) and (H,V) of type 1 BPM.

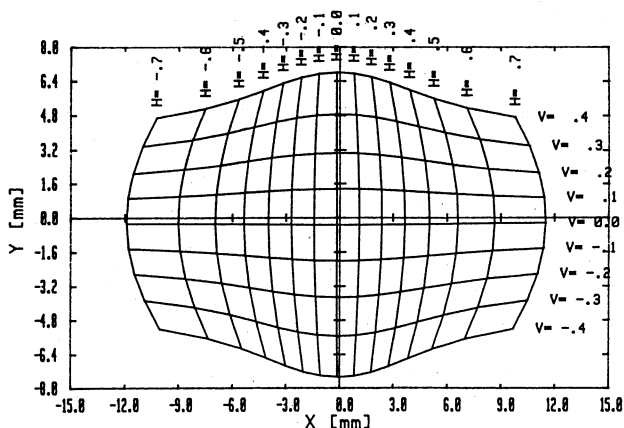

Fig. 5. An example of a calibrated relationship between (x,y) and (H,V) of type 1 BPM

The precision of the X-Y table is about 0.005 mm and the accuracy of installation of BPM pickup on the calibration system is within 0.05 mm. The accuracy of the optical sensors to set the antenna at the initial position is within 0.05 mm. Thus the accuracy of the